

CONSTRUCTING A STEREO DECODER

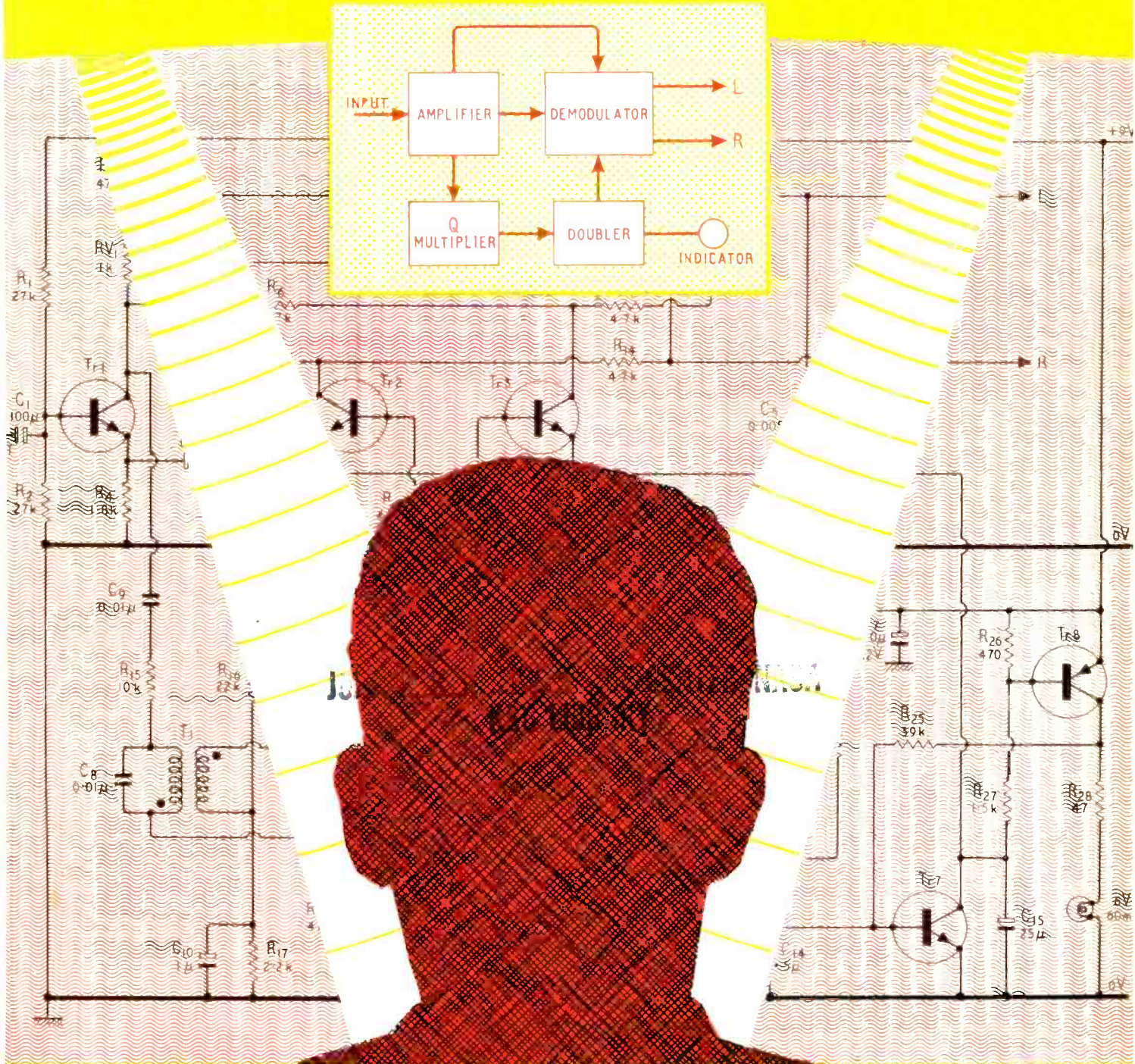

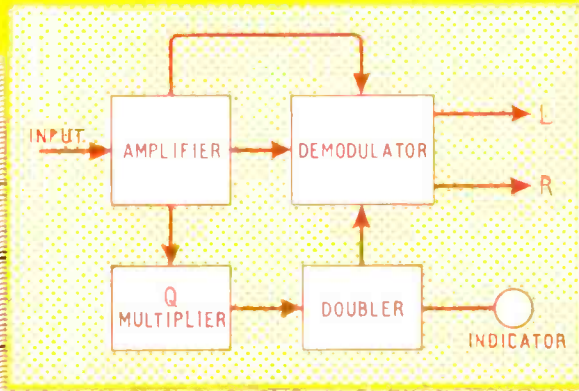



JANUARY 1967
Three Shillings

Wireless World



ELECTRONICS • TELEVISION • RADIO • AUDIO

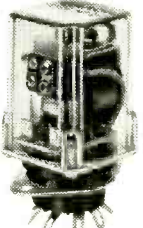

RELAYS **ex stock in 7 days** *C.S.A. APPROVED IN CANADA

| | | | |
|---|--|--|--|
| <p>*MK</p>  <ul style="list-style-type: none"> ★ 3 pole 7.5 amp ★ 5 million ops. min. ★ 12/4 each per 1000 <p>Single pole 9/7 per 1000</p> | <p>MM Contactor</p>  <ul style="list-style-type: none"> ★ 2 pole 15 amps ★ 5 million operations minimum ★ 17/8 each per 1000 | <p>*MHP Plug-in relay</p>  <ul style="list-style-type: none"> ★ 4 pole, 1 amp ★ 100 million operations ★ 13/- each per 1000 <p>SOLDER TERMS</p> <p>2 pole 8/- per 1000</p> | <p>1051</p>  <ul style="list-style-type: none"> ★ Snap action microswitch relay ★ 7.5 amp 1 million operations <p>Also available in plug-in version</p> <p>★ 7/5 each per 1000</p> |
| <ul style="list-style-type: none"> ★ 2 pole 5 amp ★ 5 million ops. min. ★ 14/8 each per 1000 | <p>*MKP Plug-in relay</p>  | <p>*MK103</p> <ul style="list-style-type: none"> ★ Single pole 3 amp ★ 1 million operations minimum ★ 5/11 each per 1000  | <p>MK403P NEW Plug-in relay</p>  <ul style="list-style-type: none"> ★ 4 pole 3 amp ★ 5 million operations minimum ★ 29/- each per 1000 <p>SOLDER TERMS</p> <p>★ 21/9 each per 1000</p> |

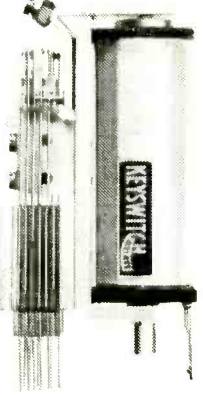
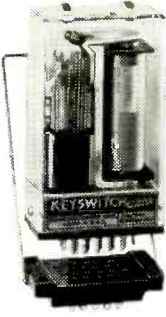
RELAYS **made to measure** APPROVALS: C.E.G.B. No. 131 & 92 · B.R. POST OFFICE KRL · U.K.A.E.A.

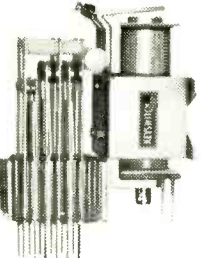
| | | | | |
|--|---|--|---|--|
| <p>P.O. 3000 RELAY</p> <ul style="list-style-type: none"> ★ Manufactured to full G.P.O. specification, also to Industrial Standards ★ Contacts up to 30 amp  | <p>P33 PLUG-IN RELAY</p>  <ul style="list-style-type: none"> ★ Plug-in version to BPO 3000 relay, made to measure for Industrial Applications ★ Contact ratings up to 10A/750V ★ Positive-lock retaining clip ★ 30 million operations minimum | <p>P.O. 600 RELAY</p> <ul style="list-style-type: none"> ★ Compact version of BPO 3000 relay ★ Contacts up to 10A ★ Sensitivities down to 30mW ★ Up to 18 contact springs  | <p>COMPONENT BOARD P304</p>  <ul style="list-style-type: none"> ★ Plug-in component board unit for low cost, easy chassis fabrication ★ 15/- each per 500 <p>FROM STOCK</p> | <p>CONTACTOR K700 RELAY</p> <ul style="list-style-type: none"> ★ High-current/high-voltage 3000-type relay ★ Contact up to 30A240V a.c. ★ Sensitivities down to 45mW ★ PTFE armature bar/lifting rods  |
|--|---|--|---|--|

KEYSWITCH RELAYS LIMITED
120/132 Cricklewood Lane · London · NW2 · Tel: Gladstone 3344
Telex: 262754 STD 01-452-3344

WW-001 FOR FURTHER DETAILS.

"Wireless World"
Iliffe Electrical Publications Ltd.,
Dorset House, Stamford Street,
London, S.E.1

Managing Director:
W. E. MILLER, M.A., M.I.E.R.E.

Editor-in-chief:
W. T. COCKING, F.I.E.E.

Editor:
H. W. BARNARD

Technical Editor:
T. E. IVALL

Editorial:
B. S. CRANK
F. MILLS
G. B. SHORTER, B.Sc.

Drawing Office:
H. J. COOKE

Production:
D. R. BRAY

Advertisements:
G. BENTON ROWELL
(Manager)
J. R. EYTON-JONES

© Iliffe Electrical Publications Ltd., 1967. Permission in writing from the Editor must first be obtained before letterpress or illustrations are reproduced from this journal. Brief extracts or comments are allowed provided acknowledgement to the journal is given.

VOLUME 73 No. 1
PRICE: 3s.

FIFTY-SIXTH YEAR
OF PUBLICATION

Wireless World

ELECTRONICS, TELEVISION, RADIO, AUDIO

JANUARY 1967

- | | | |
|----|----------------------------------|--------------------------|
| 1 | Symbols: The Common Language | |
| 2 | A Stereo Decoder | by D. E. O'N. Waddington |
| 8 | Colour Receiver Techniques—1 | by T. D. Towers |
| 13 | Cine Filming Television | by J. M. Hale |
| 23 | I.Cs in Communication Equipment | by P. J. Forrest |
| 28 | Logical Door-lock | by B. Crank |
| 33 | Transistor Metal Locator | by T. E. Estaugh |
| 41 | Data Transmission Demonstrations | by N. M. Morris |

SHORT ITEMS

- | | |
|----|--|
| 12 | TV Camera with Solid-state Image Sensing |
| 17 | Tone-operated Switch |
| 18 | TV Receiver Sound Quality Criticized |
| 18 | Motorists' Radio-telephone Network |
| 40 | Video Disc Recording |

REGULAR FEATURES

- | | | | |
|----|-----------------------------|----|-----------------------------------|
| 1 | Editorial Comment | 39 | Literature Received |
| 18 | World of Wireless | 40 | Books Received |
| 20 | Personalities | 45 | HF Predictions |
| 22 | News from Industry | 46 | January Meetings |
| 27 | Conferences and Exhibitions | 47 | New Products |
| 35 | Letters to the Editor | 54 | Real and Imaginary by "Vector" |

PUBLISHED MONTHLY (3rd Monday of preceding month). Telephone: Waterloo 3333 (70 lines), Telegrams/Telex: Wiworld Iliff-pres 25137 London. Cables: "Ethaworld, London, S.E.1." Annual Subscriptions: Home £2 6s Od. Overseas: £2 15s Od. Canada and U.S.A.: \$8.00. Second-class mail privileges authorised at New York N.Y. BRANCH OFFICES: BIRMINGHAM: 401, Lynton House, Walsall Road, 22b. Telephone: Birchfields 4838. BRISTOL: 11, Marsh Street, 1. Telephone: Bristol 21491/2. COVENTRY: 8-10, Corporation Street, Telephone: Coventry 25210. GLASGOW: 123, Hope Street, C.2. Telephone: Central 1265-6. MANCHESTER: 260, Deansgate, 3. Telephone: Blackfriars 4412. NEW YORK OFFICE U.S.A.: 300 East 42nd Street, New York 10017. Telephone: 867-3900.

silicon planar

**for audio, radio and hybrid
television applications**

Mullard now offer a comprehensive range of Silicon Planar Transistors for all new design requirements. These devices are outstanding in performance and are available at competitive prices.

Complete information is available to Design Engineers from:—

Mullard Limited · Entertainment Markets Division
Mullard House · Torrington Place · London · W.C.1
Tel: LAngham 6633 · Telex 22281

BC107

Low-frequency high-gain driver.

BC108

Low-frequency high-gain amplifier.

BC109

Low-noise high-gain A.F. amplifier.

BF115

V.H.F. mixer and oscillator for television.

BF167

'Integrated Screen' transistor for television I.F. amplifiers (A.G.C.)

BF173

'Integrated Screen' transistor for large signal television I.F. amplifier stages.

BF180

Low-noise R.F. amplifier for U.H.F. and integrated tuners.

BF181

High-gain mixer and mixer/osc. for U.H.F. and integrated tuners.

BF184

High-gain I.F. amplifier for A.M., F.M. and television sound.

BF185

R.F. and I.F. amplifier for portable radios.

Mullard

planar

WW-097 FOR FURTHER DETAILS

Wireless World

ELECTRONICS, TELEVISION, RADIO, AUDIO

Symbols: the Common Language

THE Oslo decision, or rather indecision, on colour television last October, tended to obscure other happenings at this meeting of the C.C.I.R. One of these was the recommendation that the unit of frequency should in future be known as a Hertz instead of the familiar and meaningful cycles per second. The Germans and some other Continentals have used the unit, abbreviated Hz, for many years and when one has read an article in, say, a German journal in which the abbreviation is used one has mentally said "cycles per second." Now the Americans have adopted, or are adopting, Hz. What of the U.K.? Although no international decision can be taken on the C.C.I.R. recommendation until the next Plenary Assembly of the I.T.U., which will not be until 1970, some British organizations, including the B.B.C. in certain documents, are already adopting Hz. As will be seen in the advertisements in this journal some manufacturers are also using it, but editorially we have not yet done so.

Some will consider us to be out of step, but what are the pros and cons? Certainly standardization is to be encouraged to facilitate the easy exchange of information; and it also assists in the export field. Any change, no matter how justifiable is bound to raise the ire in some, and there are many in the industry and elsewhere who cannot see the justification for this change. The main criticism is that Hz does not directly indicate the property of frequency as does c/s. However, if the consensus of opinion is to use the name Hertz, to perpetuate the memory of the German scientist who in 1880 discovered "electric waves," then we will, of course, make the change. In the meantime we would welcome comments.

From literal to graphical symbols. A correspondent in *Electronics & Power* condemns some of the symbols introduced in the new British Standard "Graphical Symbols for Electrical Power, Telecommunications and Electronics Diagrams" (BS3939) which he says reduces a circuit diagram to "an amorphous mass." The symbols in this new Standard, to quote from the introduction, "are identical with those internationally agreed within the International Electrotechnical Commission except where established usage in this country makes acceptance of the international standard impracticable at the present time. When in such cases an 'objective symbol' is shown it is intended that it be adopted as soon as practicable in the future, the aim being to achieve complete conformity with the IEC Recommendation as early as practicable." One such "objective symbol" is a rectangle for a resistor in place of the familiar zig-zag. As the correspondent in *Electronics & Power* points out the place for such a rectangle depicting the physical shape of a component without any indication of its function is on the wiring diagram. The same symbol incidentally is also used for resistance in an equivalent circuit.

As graphical symbols are intended to be an international common language, standardization is, of course, of prime importance, but we question the value of a symbol which is as featureless and ambiguous as an open box.

The issuing of a British Standard has come to be regarded largely as a matter of giving formal ratification to what has already become accepted practice in the U.K. Why, we wonder in the case of graphical symbols have B.S.I. suddenly broken away from this well-tried procedure, which few quarrel with (or even notice)? It rather looks as if their lack of initiative has made them too compliant to what, in this case, the Continental members of I.E.C. have already decided.

A STEREO DECODER

DESIGN USING N-P-N OR P-N-P TRANSISTORS

Circuit based on silicon or germanium transistors ■ $> 30\text{dB}$ channel separation ■ uses 19kc/s Q multiplier ■ shunt transistor switching demodulator ■ optional RC active filter ■ stereo indicator

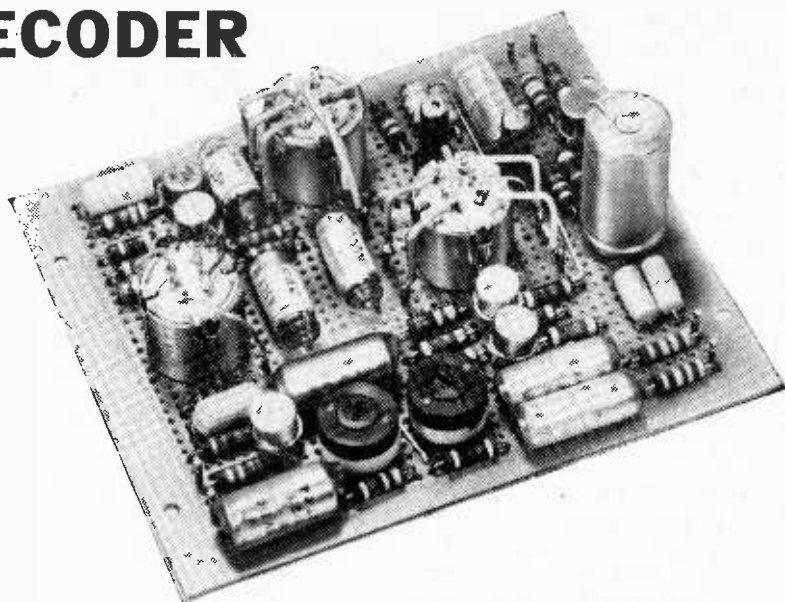

By D. E. O'N. WADDINGTON*
A.M.I.E.R.E.

NOW that the transmission of stereophonic signals in the U.K. is a reality, albeit on a limited scale, interest in decoders to enable the reception of these programmes has naturally increased. The author has been investigating the problems involved, and the circuit and techniques to be described in this article are the result.

Before attempting to design, or build, a decoder, the first essential is to understand the nature of the signal to be processed.^{1, 2} In the pilot tone system the signal is produced as follows (see Fig. 1). Two basic signals, R corresponding to the audio frequency signal intended for the right-hand loudspeaker and L corresponding to that intended for the left, are obtained from the microphones. L and R are then added in phase and in anti-phase to produce the two signals $L+R$ and $L-R$. The $L-R$ signal is then modulated on to a 38kc/s carrier in a double balanced modulator circuit which ensures that only the modulation products emerge. The $L+R$ signal, the $L-R$ modulation products and a 19kc/s pilot signal, which is phase coherent with the 38kc/s subcarrier, are all added together and this forms the signal which is to be transmitted. Fig. 2 shows the spectrum of a signal carrying only 1kc/s (slightly distorted) in one channel.

Although the signal is normally made up in this fashion, it could be generated by using a system which sampled the left- and right-hand channels alternately at a 38kc/s rate using a sine wave (see Fig. 3). This produces the same effect as described above and is, possibly, easier to understand. This sampling concept for the generation of the signal offers an easy solution to the problem of reproducing the left- and right-hand channels information as it is only necessary to use two phase-sensitive rectifiers, coherent with the sampling signal. Thus, the tasks of the decoder are as follows:—

1. pick out the pilot tone (19kc/s),
2. using the pilot tone as a reference, regenerate the sampling signal in the correct phase relationship,
3. extract the left- and right-hand channel information using phase sensitive detectors,

*Marconi Instruments Ltd.

4. matrixing. (As the phase sensitive detectors will not be 100% efficient, it will be necessary to process the signal in order to obtain adequate channel separation.)

Pilot tone extraction

The pilot tone may be extracted by a simple parallel tuned circuit as shown in Fig. 4. This method has the disadvantage that the Q of the circuit is low thus per-

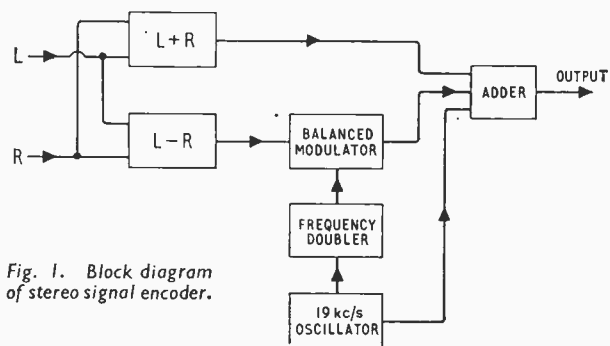

Fig. 1. Block diagram of stereo signal encoder.

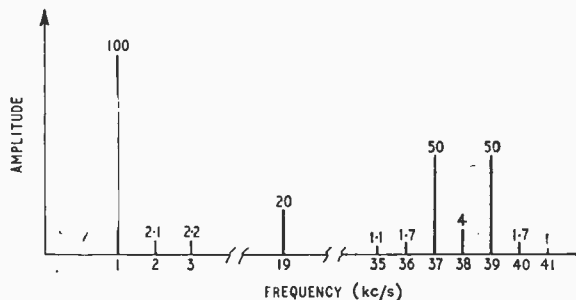

Fig. 2. Frequency spectrum at output of stereo encoder with slightly distorted 1kc/s signal in one channel.

mitting other signals, besides the 19 kc/s, through. This, in itself, is no fault as it is possible to improve the quality of the signal by further filtering. However, there is always the possibility that some non-linearity in the circuit may cause the spurious signals to modulate the 19 kc/s tone. The effect of this is to cause a degradation of the channel separation. In order to overcome this problem a *Q* multiplier circuit³ as shown in Fig. 5 is used. This works as follows. The input signal across the tuned circuit is fed, in phase, via the transformer to the base of the transistor. The output at the emitter is fed directly to the bottom of the tuned circuit, thus causing it to follow the input. At resonance, therefore, the tuned circuit looks like a very high impedance but, as the frequency is changed, its impedance falls off rapidly. As only a moderate improvement in the *Q* of the tuned circuit is necessary, the circuit has been designed to have a fairly wide stability margin.

Sub-carrier or sampling signal regeneration

There are three main methods of doing this, namely: locking a 38 kc/s oscillator to the pilot, feeding the pilot to a tuned frequency doubling circuit or full-wave rectifying the pilot and then filtering. The author has tried out all three methods and has found that, although all three methods work, the first two tend to be unsatisfactory as the input/output phase relationship changes with pilot tone level. This means that the channel separation will be very dependent upon the input signal. The full-wave rectifier system does not suffer from this defect and thus was included in the circuit. It was found convenient to feed the rectified signal direct to a simple limiting amplifier with the collector tuned to 38 kc/s. (See Fig. 9.) The biasing of this amplifier is arranged such that, until the 19 kc/s signal reaches a sufficient amplitude, the transistor is cut off thus preventing any switching signal from reaching the bases of Tr2 and Tr3. When the pilot tone threshold is exceeded, however, the base of Tr6 becomes forward biased and the switching signal is amplified. At the same time Tr7 is switched on. This removes the reverse bias from the bases of Tr2 and Tr3 and permits them to operate as normal shunt gates. (Normally Tr2 and Tr3 are cut off so that they do not interfere with the mono signals.) This same switching action is used to operate a lamp so as to give an indication when a stereo signal is being received.

Phase sensitive detection

This may be accomplished either by shunt or series gating and either method may be designed to give satisfactory results. Whichever method is used, however, the important requirement of the switching element is

Main Performance Features

Compatible with stereo or mono transmissions.
 Stereo channel separation: 30 dB or better 50 c/s—15 kc/s.
 Stereo gain: 0.3.
 Mono gain: 0.6.
 Input impedance: >10kΩ
 Distortion: <0.1% (mono)
 Noise: mono: <100 μV
 stereo: no satisfactory measurement has been made.
 Power: 9 V, 8 mA mono; 69 mA stereo.

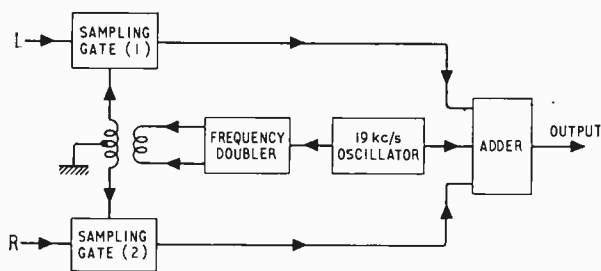

Fig. 3. Sampling method of stereo signal encoding.

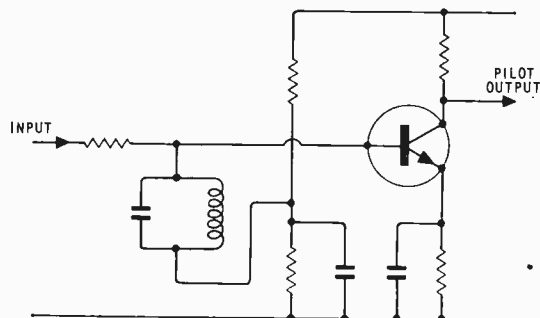

Fig. 4. Simple method of pilot tone extraction.

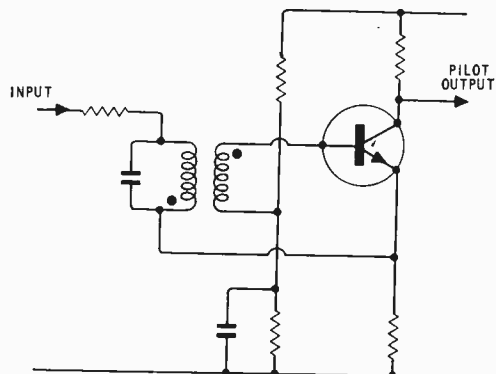

Fig. 5. *Q* multiplier method of pilot tone extraction.

that it should approximate, as nearly as possible, to a perfect switch, i.e., it should switch between open circuit and short circuit conditions without introducing any distortion or generating any "switch rate" potential in series with the output. While mechanical switches fulfil these requirements, they do not operate fast enough. Thus, we are left with semiconductors (or vacuum tubes) as switching elements.

Diodes—These are very effective switches as they have on/off resistance ratios varying from $10^3:1$ to $> 10^7:1$. However, in the "on" state there is always a potential drop across the diode, approximately 0.2 V for germanium and approximately 0.6 V for silicon. This makes them unsuitable for simple shunt gating as, inevitably, a voltage at the switching frequency is developed in series with the signal. By using two diodes in a series gate,

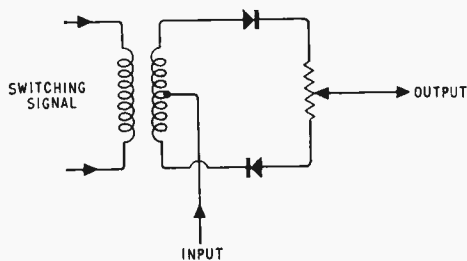

Fig. 6. Balanced diode series gate.

however, it is relatively easy to balance out the diode potentials (Fig. 6).

Bipolar transistors.—These may make very good switches as the on/off ratio is very high. The voltage drop across a transistor in the "on" state may well be less than 10 mV. Thus they are suitable both as series and shunt switches. However, when used as series switches they pose a problem as the current holding the transistor switched on must not be permitted to flow through any impedance in the signal path. This means that a transformer with an isolated secondary winding must be used. (Fig. 7.) The shunt gate poses no such problem and has been used in this design.

Field effect transistors.—These make the best semiconductor switch as the gate requires only a potential to switch the channel on and off and there is no voltage drop between the source and the drain when the device is on. F.E.T.s. may thus be used either as shunt or series gates without the necessity for any of the precautions required by diode and transistor switches. Fig. 8 shows a configuration which was tried, with a considerable degree of success. It was not used in the final version of the decoder because the performance of the bipolar shunt gate was good enough and, at present, the price of field effect transistors is much higher than that for bipolars.

Matrixing

When using phase sensitive detection matrixing is an unfortunate necessity as a certain amount of the L signal will always be present in the R signal and vice versa. Thus if the right hand output is $R+0.1L$ it is necessary to add $-0.1L$ to this signal to cancel out the unwanted signal. In Fig. 9, it is seen that this

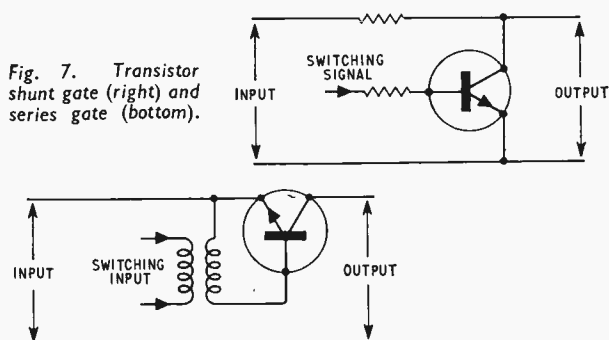

Fig. 7. Transistor shunt gate (right) and series gate (bottom).

antiphase signal is produced at the collector of Tr1 and is added to the signal at the output.

Construction

The layout of the decoder is not at all critical but the layout shown in Fig. 10 may be used as a guide. The main point to watch is the coil winding as, reversing the phase of T1 will result in the Q multiplier not multiplying and a loss of 19 kc/s gain. Reversing the phase at T3 will invert the channels. The circuit may be used in two forms with either negative or positive earth. Three resistors and the transistors are different, and are specified in the components list.

Setting up

The performance of a decoder, unfortunately, depends very much on the accuracy with which it and the receiver with which it is to be used, have been set up. This setting up consists of three separate parts:—

1. Setting the pilot/sub-carrier phasing.
2. Adjusting the channel separation.
3. Tuning the receiver for optimum phase response.

Phase adjustment.—The test gear necessary to do this is an accurate 19 kc/s source and an oscilloscope. If no other method of checking the 19 kc/s source frequency is available, it is possible to use the transmitted pilot tone as a standard. This involves tuning T1 to approximately 19 kc/s, applying a multiplex signal to the input of the decoder and then, using the signal at the collector of Tr4 as a standard, to set the source to the same frequency (Lissajous figure method)⁴. Having obtained your accurate 19 kc/s source, the method is as follows. Connect the source to the input of the decoder and, keeping the input level low enough to prevent limiting, adjust T1 for maximum output at the collector of Tr4 and T2 and T3 for maximum output at the collector of Tr6. Increase the input until Tr6 limits when the input should be about 60 mV r.m.s. Compare the phase of the signal at the input with that at the point B by connecting the input signal to the Y input of the oscilloscope and the signal at point B to the X input. It will probably be necessary to adjust T2 in order to obtain the characteristic figure of eight (Fig. 11) which indicates that the phasing is correct.

Channel separation.—As far as the author knows, this may only be set up using a suitable stereo test signal. The technique is to apply a multiplex signal containing only L information to the input and to adjust RV2 for minimum output on the R channel. This is then repeated

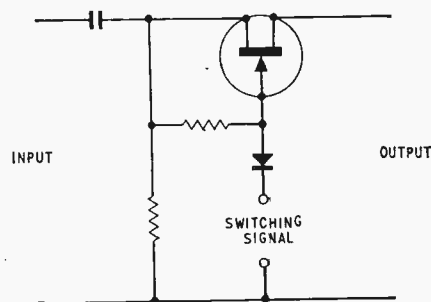

Fig. 8. Series gate using field-effect transistor.

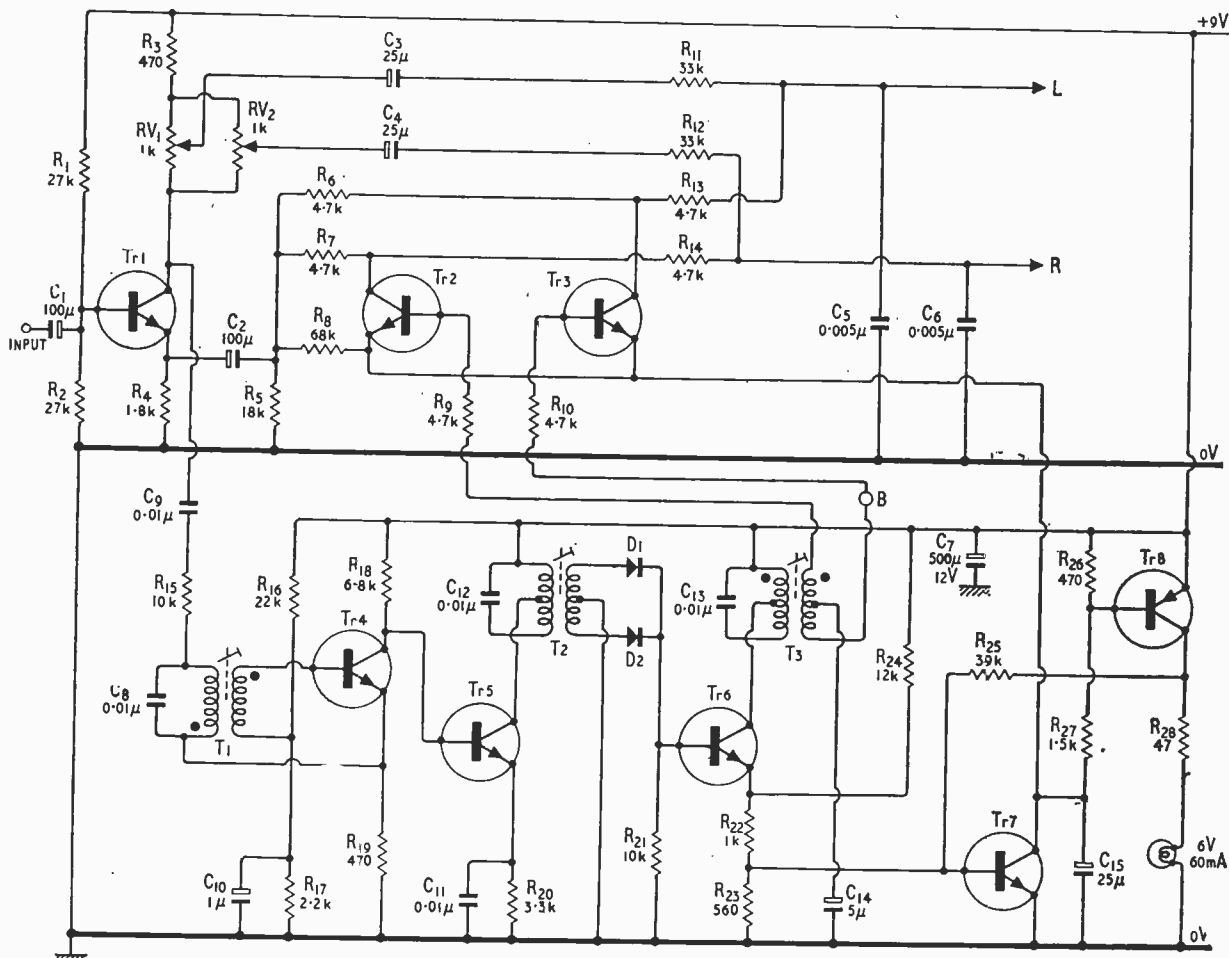

Fig. 9. Stereo decoder circuit (negative earth version). In the positive earth version, polarity of electrolytic capacitors is reversed, resistors R_1 , R_{16} and R_{18} altered in value and p-n-p transistors used (apart from Tr8).

LIST OF COMPONENTS

Resistors

Values as shown in Fig. 9. For the positive earth version R_1 , R_{16} and R_{18} are 47 k Ω , 27 k Ω and 5.6 k Ω respectively. R_{28} should be made 150 Ω if 40 mA lamp is used.

Capacitors

| | |
|--|---|
| C_1 100 μ F 6 V | C_9 0.01 μ F paper |
| C_2 100 μ F 6 V | C_{10} 1 μ F 50 V |
| C_3 25 μ F 15 V | C_{11} 0.01 μ F paper |
| C_4 25 μ F 15 V | C_{12} 0.01 μ F \pm 1% poly-styrene |
| C_5 0.005 μ F paper | C_{13} 0.01 μ F \pm 1% poly-styrene |
| C_6 0.005 μ F paper | C_{14} 5 μ F 15 V |
| C_7 500 μ F 12 V | C_{15} 25 μ F 15 V |
| C_8 0.01 μ F \pm 1% poly-styrene | |

Notes:

- All resistors are 10% $\frac{1}{2}$ -watt types.
- The voltage ratings of the electrolytic capacitors are not critical.
- As mentioned in the text, the direction of winding of T1 and T3 is important. In each case, the dots denote the start of the winding.
- The prototype was built on "Lektrokit" board.

Semiconductor devices

| | Negative earth version | Positive earth version |
|---------------|---|--------------------------------------|
| Tr1, Tr4, Tr5 | BC108. (2N3706, 2N3707, BCY42, PEP5, 2N914, 2N929, 2N2926.) | 2N404. (NKT122, OC42, 2G302.) |
| Tr2, Tr3 | BC108. (2N914, OC139, 2N1304.) | 2N404. (NKT122, OC45, 2G308, OC201.) |
| Tr6, Tr7 | BC108. (2N3706, BCY42, PEP5, 2N914.) | OC201. (2N3703, NKT20441.) |
| Tr8 | ACY22. (OC72, OC83, NKT212, 2N404.) | 2N1304. (OC139.) |
| D1, D2 | OA47. (OA5, AAZ13, HG5004, CG85H.) | |

Transformers

| | | | |
|----|-----------|-------|---------------------------------------|
| T1 | Primary | 112 t | 36 s.w.g. enam. (7.02 mH) |
| | Secondary | 116 t | 36 s.w.g. |
| T2 | Primary | 112 t | 36 s.w.g. " tapped at 56 t (7.02 mH) |
| | Secondary | 112 t | 36 s.w.g. " tapped at 56 t (1.755 mH) |
| T3 | Primary | 56 t | 32 s.w.g. " tapped at 28 t (1.755 mH) |
| | Secondary | 56 t | 32 s.w.g. " tapped at 28 t |

All coils wound on Mullard 18 mm ferrite core LA 2532.

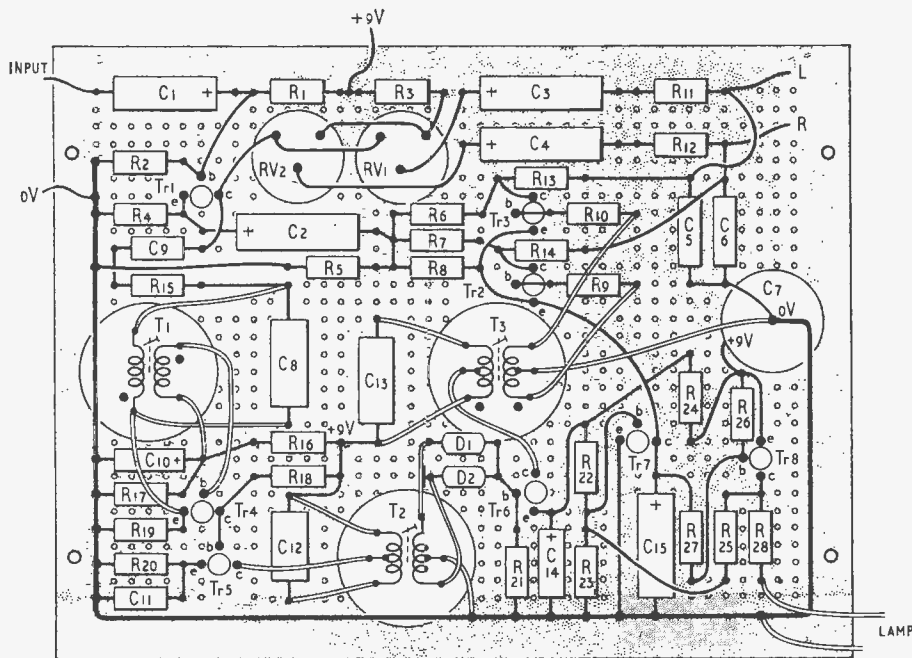

Fig. 10. Diagram to show suggested layout and wiring. The components and wires shown unfilled are on the top side of the board (Lektrokit) and the wires shown solid on the other side, as made clear below ▼.

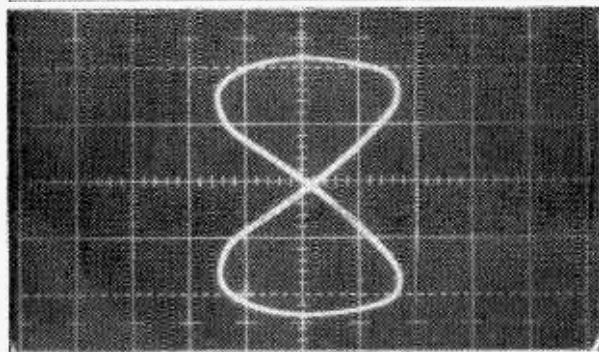
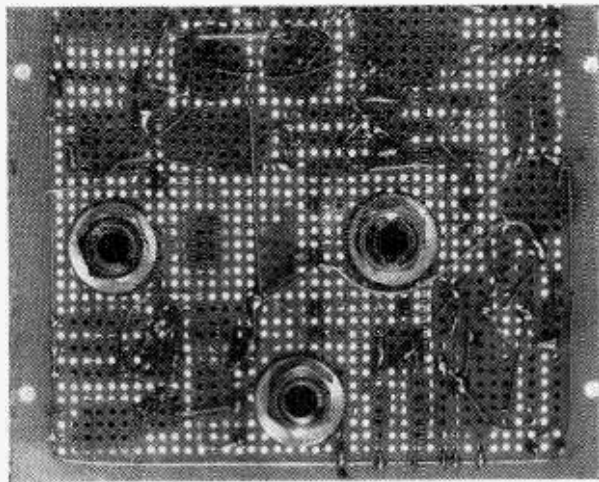

Fig. 11. Pattern obtained when phase relationship between 39 kc/s waveform at B (Fig. 9.) and 19 kc/s input is correct.

using R information and adjusting RV1 for minimum output on the L channel. If no test gear is available, setting the controls to mid-travel will result in a channel separation of better than 20 dB.

Receiver adjustment.— In addition to the requirement for extra i.f. bandwidth it is desirable that the phase response should be good. A poor phase response results in non-linear distortion of audio frequency signals and also in degradation of the channel separation. Thus there are two relatively simple methods of setting up the phase response, provided always that access is available to suitable test gear.

The first method consists of applying a signal, modulated with a pure tone, to the input of the receiver and monitoring the output with a distortion factor meter. The

tuning of the i.f. and discriminator transformers is then adjusted to give a compromise between maximum output and minimum distortion.

The second method is to apply a signal modulated with a multiplex signal to the input of the receiver. The i.f. and discriminator tuning is then adjusted to give minimum cross talk.

Performance

Although an attempt has been made to draw up a comprehensive list of standard tests to be carried out on stereo decoders, it is difficult to decide which of these are necessary to specify the performance. In view of this, the author decided to treat it, as far as possible, as a simple audio amplifier and to assess the following:—

- (a) frequency response.
- (b) distortion.
- (c) noise.
- (d) maximum output.
- (e) minimum pilot tone level.
- (f) channel separation.

The last two tests are the only ones which are peculiar to stereo decoders.

(A) The frequency response was plotted with both mono and stereo signals and the results were so startlingly the same that it was only possible to draw one graph which is virtually the 50 μ s de-emphasis characteristic.

(B) Using a 1 kc/s signal to test under mono conditions, the total harmonic distortion was found to be 0.1%. The stereo test was more difficult to carry out satisfactorily as the only multiplex source available had the spectrum shown in Fig. 2. However, the author realized that the test could be carried out using a simulated test signal, i.e. if $L=R$, then there will be no $L-R$ information and a simple a.f. signal plus a 19 kc/s pilot tone is equivalent to the multiplex signal. This made the test quite easy to carry out and it was found that the distortion, although slightly worse than that for mono, was still less than 0.1%. (It is interesting

to note that the spectrum shown in Fig. 12 is the output corresponding to the test signal shown in Fig. 2.)

(C) Noise was measured using a signal consisting only of the pilot tone. The total output from the decoder was then measured using a broad-band millivoltmeter and was found to be 5 mV. However, it should be appreciated that the output at 19kc/s was 5 mV and at 38 kc/s 3 mV.

(D) Due to the inefficiency of the phase sensitive detectors the maximum output with stereo signals will be about $\frac{1}{2}$ of that with mono. Thus the maximum outputs are 0.3V for stereo and 1V for mono.

(E) The minimum pilot tone level required to operate the decoder (switch Tr7 on) is 40 mV.

(F) The channel separation was fairly difficult to measure accurately as it involved setting up the signal source for maximum separation at each test frequency. Due to distortion in the encoder, it was impossible to set the input channel separation to better than 40 dB with any degree of confidence. Despite this, the separation measured was better than 30 dB from 50 c/s to 15 kc/s (see Fig. 13).

Some practical notes

(1) It is advisable to use the decoder with a receiver which has a.f.c. or is crystal controlled. If this is not done, channel separation will depend upon tuning accuracy and will also be liable to drift with the local oscillator.

(2) Although pulse-counting f.m. discriminators are ideal from the point of view of linearity and output, the fact that they use a low intermediate frequency may be an embarrassment. This is because it is possible for harmonics of the 38 kc/s subcarrier to beat with the i.f. signal. Thus an adequate low pass filter should be fitted at the input of the decoder. During tuning in, the decoder is likely to switch on at the instant when the i.f. goes through 19 kc/s.

(3) As the output of the decoder is high impedance (in order to provide de-emphasis simply), it is advisable to run it into an input impedance of not less than 50 k Ω .

(4) As there will probably be some variation in the inductance of coils wound by hand, the easiest way to ensure the correct inductance is to wind the secondary on first. The primary is then wound on the outside with a few extra turns added. The transformer may then be connected into the circuits on flying leads and the tuning checked. If the slug needs to be fully out of the coil to achieve resonance, fewer turns are required on the coil and vice versa.

(5) In some cases where the decoder is used in conjunction with a tape recorder, there is the possibility that residual high frequency components of the signal may beat with the bias oscillator producing undesirable "birdies." This may be overcome by connecting a low pass filter in the signal path. Fig. 14 shows the circuit

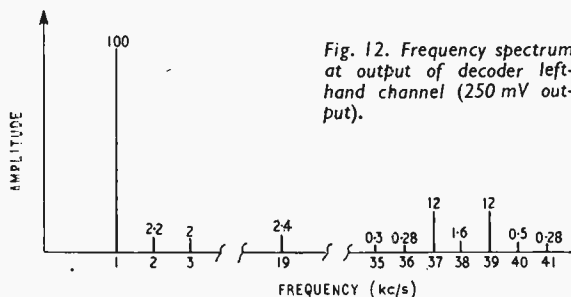

Fig. 12. Frequency spectrum at output of decoder left-hand channel (250 mV output).

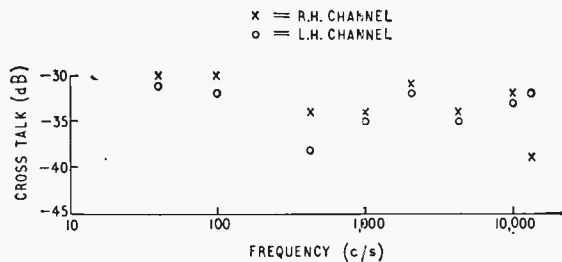

Fig. 13. Channel separation (experimental results).

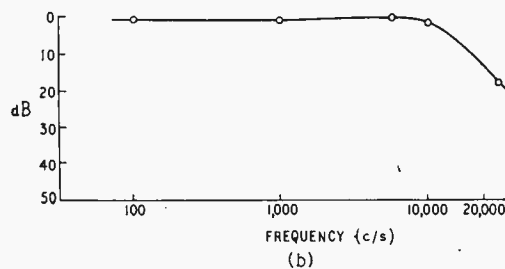
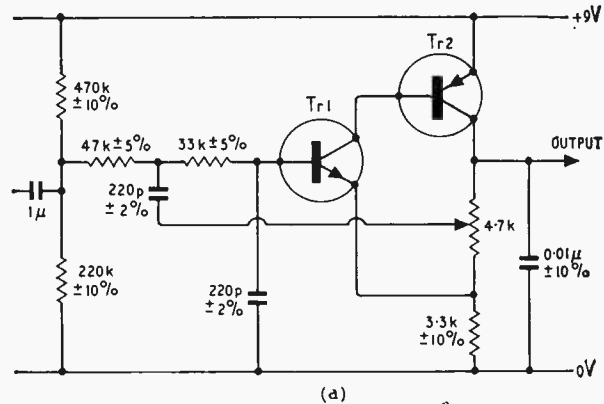

Fig. 14. (a) Active filter to give attenuation of frequencies liable to beat with tape recorder bias frequency (Tr1: BC108, 2N929, 2N3707 or 2N2926; Tr2: 2N3703, OC201, NKT2044). (b) Response of filter.

of an active filter which has been designed to be connected directly to the output of the decoder. In order to obtain the frequency response shown, it is necessary to adjust the variable resistor to make the transmission at 10 kc/s equal to that at 1 kc/s. This method of filtering has been chosen because it produces results similar to an LC filter but does not present matching problems.

Acknowledgments.—The author would like to thank Marconi Instruments Ltd. for permission to publish this article and Mullard Ltd., who supplied the necessary semiconductors.

REFERENCES

1. Receiving Stereo Broadcasts. *Wireless World* Sept. 1966.
2. Stereophonic Broadcasting and Reception. G. J. Phillips and J. G. Spencer *Radio and Electronic Engineer* June 1964.
3. Active Impedance Converters, F. Butler *Wireless World* Dec. 1965, p. 601.
4. Radio Laboratory Handbook, M. G. Scroggie 6th Edition p. 277 (Iliffe).
5. Suggestions Concerning Measurement of Stereophonic F.M. Receivers, A. L. R. Limberg *I.R.E. Trans* vol. BTR-10, May 1964.

Colour Receiver Techniques

1.—THE COLOUR TELEVISION SIGNAL

By T. D. TOWERS*, M.B.E.

At last it looks as though (touch wood!) we will have colour television programmes in the United Kingdom in 1967. Many *Wireless World* readers who have hitherto watched the "battle of the systems" with mild interest and often little understanding now must begin to feel that they cannot any longer put off "finding out what colour television is all about." This article, written with the ordinary mortal in mind, is intended to give some account of the PAL colour television signal currently being put out on a test basis by the B.B.C. (and likely to be what the colour receiver will have to handle when actual programmes start).

Colour television transmissions on the air

At the time of writing, anyone with a suitable colour television receiver and near enough to London can tune in to the B.B.C. trade test colour transmissions being put out every afternoon, Monday to Friday, from 2 to 5 p.m., with additional evening sessions from 6.10 to 7 p.m., on Wednesdays, Thursdays and Fridays.

These transmissions, on the 625-line, 50 fields/second standard, are radiated primarily on BBC2 from Crystal Palace in South London, but relay stations at Tunbridge Wells and Hertford also put them out. All three transmissions are on u.h.f. in Band V: Crystal Palace on Channel 33 (565.5-573.5Mc/s), Tunbridge Wells on Channel 44 (653.5-661.5Mc/s) and Hertford on Channel 64 (813.5-821.5Mc/s).

How far from these transmitters satisfactory colour reception will be possible is yet to be seen from field experience with programme material. In the case of black and white on BBC2, a fairly satisfactory picture can in favourable circumstances be obtained in Cambridge, some 60 miles from Crystal Palace. The field strength in Cambridge has been nowhere near the $3,000\mu\text{V}/\text{metre}$ which some pundits proclaim is necessary in Band V for satisfactory signal/noise ratio in receiving

monochrome TV transmissions. Despite this, it has been possible sometimes to use the Crystal Palace BBC2 transmissions for experimental colour receiver work in Cambridge. You can decide for yourself to some extent whether you will be able to receive colour from Crystal Palace now by picking up in black and white on a "normal" BBC2 monochrome receiver the TV colour trade test transmissions mentioned above.

Carrier frequencies in transmission channel

The colour system used has to allow the reproduction of colour transmissions as black-and-white pictures on existing BBC2 monochrome receivers (compatibility). Also, it should reproduce monochrome transmissions on colour receivers as high-quality, black-and-white pictures (recompatibility). To this end, the colour transmissions use the standard, 8-Mc/s-wide, u.h.f. channels with the sound and picture brightness information on the existing black-and-white frequencies within the channel, and with the colour picture information at a new third frequency.

Fig. 1 shows the location of the carrier frequencies within the channel, measured from the low frequency end, with monochrome and colour shown separately for comparison.

In the case of B.B.C. Channel 33, these standard carrier locations resolve into: (1) 567.25 Mc/s=colour luminance and monochrome vision, (2) 571.68 Mc/s=colour-only chrominance, and (3) 573.25 Mc/s=sound. (For the newcomer to the field, "luminance" is the brightness or black-and-white content of the colour signal, while "chrominance" is the colour content in terms of its saturation and hue.)

The carrier frequencies within the channel have been carefully selected in the first instance to ensure the best possible picture from colour transmissions, whether received on monochrome or colour receivers.

From the basic standard specification of 625-lines, 50 fields/second we have:

(a) f_F =field frequency=50 c/s (not locked to mains),

(b) f_L =line frequency=50 × 625=15,625 c/s.

For the first actual carrier in the channel, reckoning frequency as from the low-frequency end, we have:

(c) f_{L1} =colour luminance carrier frequency at 1.75 Mc/s.

This spacing from the lower end of the channel is to leave room for the lower sidebands of the vestigial-sideband-type transmission used on the carrier. The next carrier up the channel is the "colour subcarrier" specified by:

(d) f_C =colour chrominance subcarrier frequency at 6.18 Mc/s.

The actual value of f_C (generated at the transmitter, as distinct from its relative position in the channel) is $4,433,618.75 \pm 1$ c/s, and since it is a subcarrier superimposed on the main (luminance) carrier, this figure is its spacing from the luminance carrier. The position of f_C in the channel is computed by a formula

$$f_C = f_{L1} + f_F/2 + (284 - 1)f_L$$

The detailed basis of this last formula is a little too com-

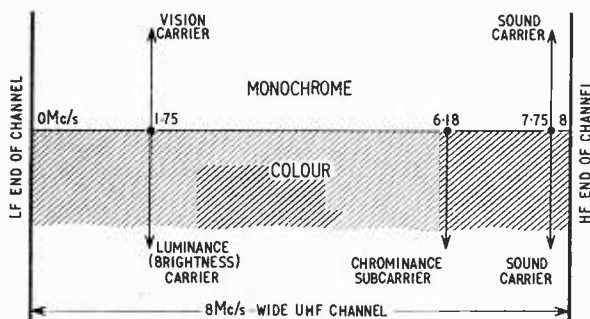

Fig. 1. Location of information carrier frequencies within u.h.f. channel used for both monochrome and colour transmission. This illustrates how black-and-white and sound information carrier frequencies are the same in both transmissions, while colour information in the colour transmission is on a separate subcarrier not present in the black-and-white transmission.

*Newmarket Transistors Ltd.

plex for discussion here, but it should be noted that the luminance-to-chrominance inter-carrier spacing includes a "half-field offset" in the term $f_H/2$, and a "quarter-line offset" in $(284-1)f_L$.

All that remains now in the channel is the sound carrier. Here the spacing from the low-frequency end is (c) $f_s = \text{sound carrier frequency at } 7.75 \text{ Mc/s}$.

This carrier is set at $f_s = f_M + 6 \text{ Mc/s}$, i.e., it is precisely 6 Mc/s offset from the luminance carrier. Also, you can see it lies 0.25 Mc/s below the top end of the channel, and thus falls 2 Mc/s ($0.25 + 1.75$) below the luminance carrier of the next higher-frequency "adjacent" channel.

How information is squeezed into the channel

On to the three carrier frequencies (luminance, chrominance and sound) within the passband of the transmission channel, eight vital streams of information are compressed to be sorted out in due course by the colour receiver. These are (1) sound, (2) line sync, (3) field sync, (4) picture brightness (luminance), (5) colour hue, (6) colour saturation, (7) reference colour carrier frequency, and (8) reference colour carrier phase. Each of these will be discussed separately below, but, to give an overall picture of how the information is multiplexed, Fig. 2 shows how the composite carrier amplitude across the channel is made up.

From what has been said already, it will have been gathered that the basic carrier is the luminance one, and that the vision information is conveyed as modulations on this. The luminance video waveform (with line and field sync) is modulated directly on this main carrier. The chrominance is modulated indirectly on to it via a suppressed subcarrier, 4.43 Mc/s from the main carrier ("suppressed" because the subcarrier itself is removed before modulating the main carrier and only the sidebands are transmitted). The a.f. signal sound is modulated onto a sound carrier spaced 6 Mc/s from the main vision carrier.

In the Fig. 2 diagram, (a) shows the band of frequencies resulting from the luminance modulation, the frequency response of the transmission system being nominally flat to 5.5 Mc/s. With double-sideband transmission this would lead to an 11 Mc/s-wide band centred on the luminance carrier at 1.75 Mc/s from the bottom end of the channel. However, in the vestigial sideband transmission method used for channel-width economy, the lower sidebands are attenuated from 1.25 Mc/s below the carrier and the luminance response is kept within the channel as at (d).

The chrominance modulation is narrower-band than the luminance, and nominally

extends out to 1 Mc/s only (the system response being flat over this band), as shown at (b) in Fig. 2. Modulated onto the chrominance sub-carrier, this gives a 2 Mc/s wide band of frequencies within the channel as at (c).

The sound modulation (f.m. with 50 kc/s peak deviation) results in a band of frequencies some 150 kc/s wide as at (c) in Fig. 2. This, modulated on the sound carrier, leads to the response within the channel as at (f).

The three modulations are finally combined into the composite channel spectrum shown at (g) in Fig. 2. The immediate thought that springs to mind is: "How is it possible at the receiver to sort out the three lots of information when they fall together in the channel?" This is where the choice of the carrier frequencies is so important. Harking back to the section on carrier frequencies, you will note that the colour subcarrier is spaced from the luminance carrier by a frequency difference which includes a quarter-line frequency and a half-field frequency. As a result of these offsets, the chrominance subcarrier sidebands tend to interleave between the luminance sidebands, and give minimum cross-talk between the two sets of sidebands. Moreover, different modulation methods—amplitude and quadrature amplitude—are used.

As to the sound signals, since these are frequency-modulated with a relatively narrow spread of sidebands, the spacing of the carrier at a full 6 Mc/s away from the luminance carrier, and 1.58 Mc/s from the chrominance carrier, reduces interference to acceptable limits.

Information associated with one picture line

Having considered how the luminance, chrominance and sound information is fitted into the transmission channel, let us now consider how it is distributed in time as it arrives at the receiver aerial. The easiest way is to look at the waveform signal which gives rise to one picture line. Fig. 3 shows, simplified somewhat, a diagram of a single line of the 625/50 colour vision signal. Signal voltages are represented by distances measured vertically,

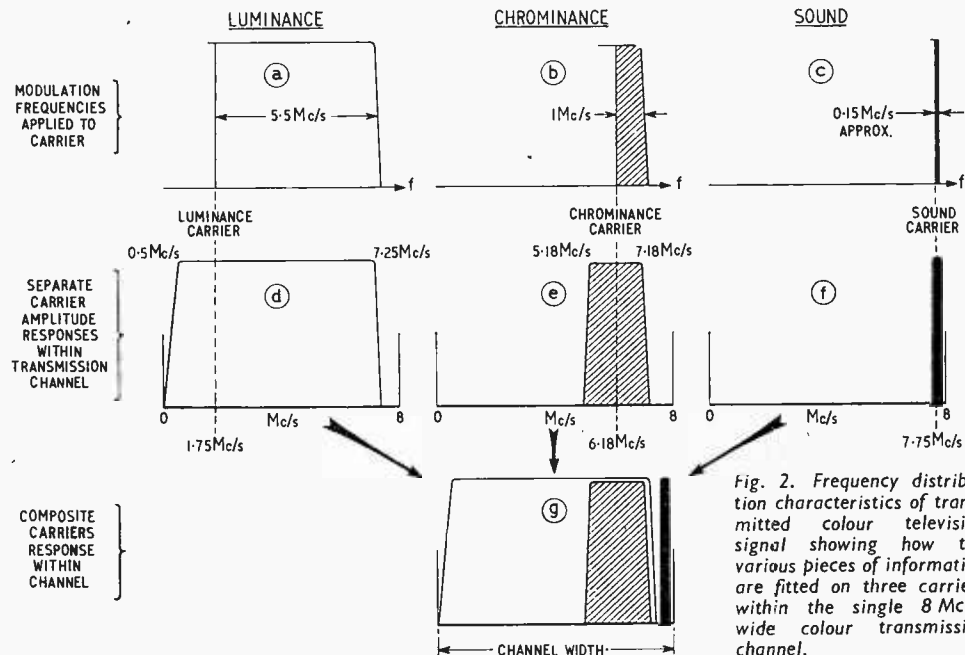

Fig. 2. Frequency distribution characteristics of transmitted colour television signal showing how the various pieces of information are fitted within the single 8 Mc/s-wide colour transmission channel.

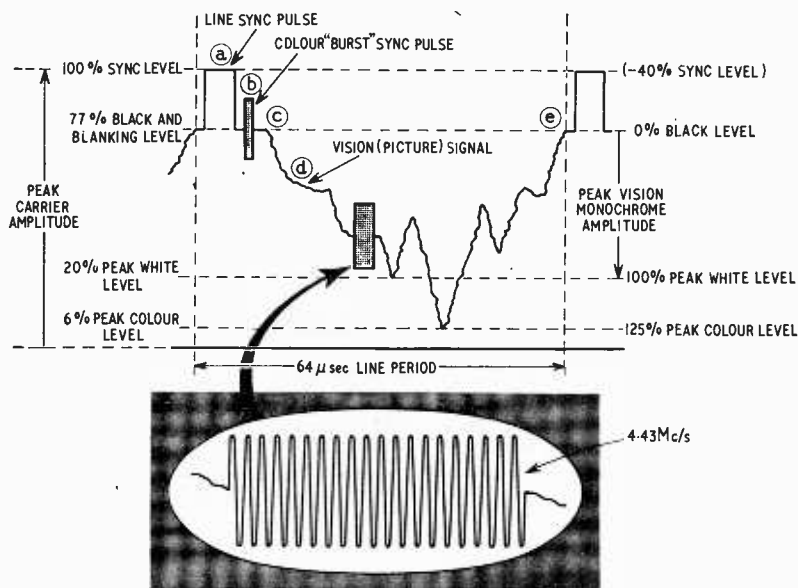

Fig. 3. Waveform of single line of 625-line, 50 fields per second, colour transmission. Detail below shows how an area of strongly saturated colour appears in the waveform.

and time horizontally. (Note that this does not include the sound signal.)

The main serial features of the line waveform in Fig. 3 are the line sync pulse at (a), the colour synchronizing "burst" or pulse at (b) and the vision signal (c, d, e).

In time, the whole line occupies 64 μ s. Within this, the line sync pulse takes up about 5 μ s, the colour burst 2.5 μ s and the vision signal 52 μ s; for the small remaining time, the signal is clamped at black level.

Amplitude-wise, the first significant feature is the inverted, negative modulation of the vision signal. By this, black is represented not as zero carrier, as some might expect, but as 77% of the peak carrier amplitude. Next it will be seen that increasing video amplitude is represented by reducing carrier amplitudes down to a peak colour amplitude of about 6% of the full carrier amplitude.

This picture-information part of the signal is, of course, the voltage resulting from the vectorial addition of the chrominance signal to the luminance (black-and-white) waveform. In Fig. 3 this is illustrated by the short sequence of cycles of subcarrier frequency (magnified below), which would result from a narrow area of strong colour (with luminance, hue and saturation constant across its width) appearing in the picture.

The line sync pulse lies upwards in the "blacker than black" region from the 77% black level to the 100% peak carrier amplitude. The colour burst consists of 10 cycles of sinewave oscillation at the subcarrier frequency, 4.43 Mc/s. It has the same peak-to-peak amplitude as the line sync pulse amplitude, but is located at a lower level, being centred on the black level.

Line sync pulse details

The line sync pulse, discussed briefly above, is important because it controls the start of the line timebase sweep in the receiver and it is worth looking a little more closely at it. Fig. 4 gives an enlarged diagram with more detail. The sync pulse proper is preceded by a 1.55 μ s "front porch," (a)-(b), designed to enable the pulse to start from black level, even when bright patches appear towards

the right hand side of the picture, i.e. at the end of the previous line. The 4.7 μ s sync pulse itself, (b, c, d, e) has a rapid 0.3 μ s rise time, to establish the timebase trigger point precisely, and a fast, 0.3 μ s, fall time, returning to set the black level in adequate time to clear the colour burst following.

The 2.5 μ s colour burst, (f)-(g), starts 0.8 μ s after the end of the line sync pulse, and lies within the 6 μ s "back porch," (e)-(h). The vision signal starts at the end of the back porch.

Except for the back-porch colour burst, which is peculiar to colour, the line sync pulse waveshape is the same for monochrome and colour.

To complete the picture of the time distribution of the vision signals, Fig. 5 shows how pulses are provided to synchronize the start of each vertical scan or field. "Field" here is taken as 312½ lines, two interlaced fields sequentially making up a complete 625-line picture. The field from line 1 to 312½ is known as "even"

and from line 312½ to 625 as "odd."

Diagram (a) in Fig. 5 shows the frame sync pulses for even fields, i.e., fields in which the vision signal ends on a full line, and which in 625-lines means fields starting at line 1. Up to line 622 of the previous odd field, the regular 4.7 μ s line pulses and the vision modulation can be seen. From line 623½ the vision signal is blanked out for 20 lines. As soon as the field blanking starts, there comes a train of five short, half-length, 2.3 μ s, equalizing pulses at half-line period of 32 μ s. These equalizing pulses are to cut out the vision signal long enough to ensure that the first of the group of five broad, 27.3 μ s, pulses that constitute the field sync pulse proper

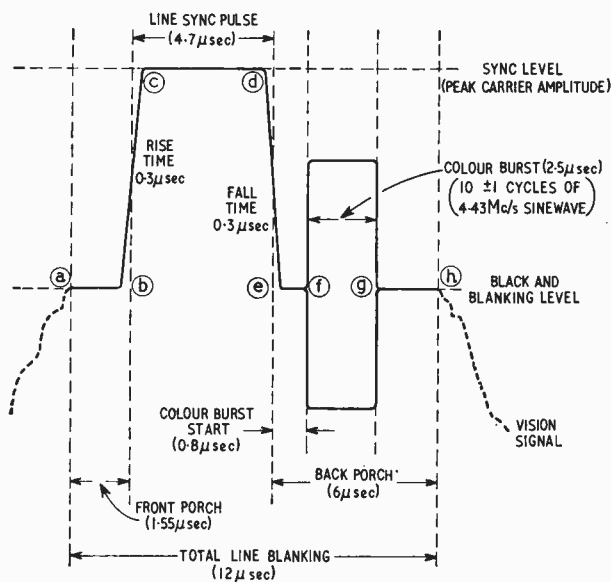

Fig. 4. Details of line sync and colour burst pulses in 625-line, negative picture modulation colour transmission.

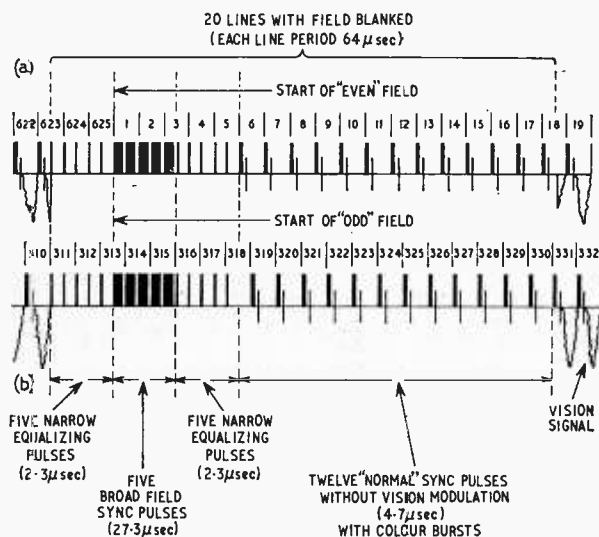

Fig. 5. General details of field sync pulse composition for (a) "even" and (b) "odd" fields.

starts from the true black level. This enables the receiver to start line 1 of the even field at a precise regularly spaced interval to ensure satisfactory interlacing of the lines in different fields. The five broad pulses that constitute the field sync pulse are also spaced at half-line period of $32\mu\text{s}$. They are followed by a further five short, half-line-period-spaced, equalizing pulses to allow the receiver to cut off the field synchronizing pulse at a precisely repeatable point and thus avoid irregularity in the duration of the vertical sweep. From line 6 to the middle of line 18, the normal line sync pulses with colour bursts take up again, but without vision signal. From the middle of line 18 onwards, the vision modulation returns, and we have the full signal again.

To complete the picture (b) in Fig. 5 shows the corresponding field sync pulse provisions for the odd field, i.e., fields with vision information ending on a half line, which on the 625-line system means fields starting on line $312\frac{1}{2}$.

Because 20 lines of vision signal are suppressed out of a total of $312\frac{1}{2}$ per field, 625-line television becomes in reality $625 - 2 \times 20 = 585$ -line only. Similarly, looking back to the line waveform of Fig. 3, we see that vision signal is available for only $52\mu\text{s}$ out of a total of $64\mu\text{s}$.

Except for the colour bursts appearing during the latter part of the field blanking in lines 6-18, and 319-330 (see Fig. 5), the field sync waveforms for the colour transmission are the same as for standard 625/50 monochrome.

Colour burst details

So far, we have seen the colour burst in Fig. 4 as a $2.5\mu\text{s}$ train of 10 cycles of 4.43 Mc/s sinewave, following closely after the line sync pulse, symmetrical about the black level, and with a peak-to-peak value equal to the line sync pulse amplitude. We must examine more closely what it actually does.

We noted earlier that the chrominance information is transmitted on a suppressed chrominance subcarrier at 4,433,618.75 c/s from the luminance carrier. This subcarrier is phase-modulated for colour hue and amplitude modulated for colour saturation. When the signal reaches the receiver, the suppressed subcarrier has

to be reinserted to enable the hue and saturation information in the sidebands to be extracted for controlling the drives to the colour display tube. To this end, the receiver has a local oscillator (the colour reference oscillator) operating at 4.43 Mc/s. This must be accurately synchronized with the original suppressed subcarrier at the transmitter. The colour burst—a sample of the transmitter subcarrier frequency—is the reference that is used to ensure complete synchronism. The receiver compares the phase of the local carrier reinsertion oscillator with the phase of the colour burst, and produces correcting voltages that bring the local oscillator exactly into phase (and thus frequency) synchronism with the burst waveform and the original subcarrier. Although the colour burst is only sent out for a short period at the beginning of each line, the local oscillator correction circuit works in a sort of flywheel sync arrangement that holds the synchronism throughout the whole line.

It is not the purpose of this article to discuss in detail the PAL system of colour transmission, but it should be noted that the colour picture signal has a composition given by

$$E_M = E_Y + [0.493(E_B - E_Y)\sin 2\pi f_C t \pm 0.877(E_R - E_Y)\cos 2\pi f_C t]$$

where $E_Y = 0.30E_R + 0.59E_G + 0.11E_B$
 f_C = chrominance subcarrier frequency, 4.43 Mc/s
 E_Y = instantaneous voltage of the luminance signal conveying brightness information
 E_B, E_G, E_R = instantaneous voltages corresponding to blue, green and red signals.

For the accurate reproduction of colour, the receiver must be able to reinsert a colour subcarrier with the correct frequency and zero phase reference. In some systems, the same zero phase reference is transmitted on every line colour burst, and in these the reference chosen is at 180° (i.e. in opposite phase to the $E_B - E_Y$ component). In the PAL system, the $E_R - E_Y$ component phase is reversed on every line, as indicated by the \pm sign in the formula for E_M above. In earlier versions of the PAL system, the fixed 180° reference was chosen for the colour burst, but in the present version, a "swinging" colour burst is used. In this, the phase reference on alternate lines is $180^\circ \pm 45^\circ$, the "+" being for lines with $+(E_R - E_Y)$ component and the "-" for lines with $-(E_R - E_Y)$. The phase reference for the E_M equation then becomes the average of the phase excursions of the colour bursts, i.e. the same 180° used in systems with non-swinging colour bursts. As a result, the burst becomes $\sin(2\pi f_C t + 3\pi/4)$ for $+(E_R - E_Y)$ lines, and $\sin(2\pi f_C t + 5\pi/4)$ for $-(E_R - E_Y)$.

To bring together all features of the colour television signal discussed so far, it might pay to consider the colour bar test signal put out by the B.B.C. at present. This takes the form of eight vertical, equal-width stripes filling the television screen, and ranging from white on the left through yellow, cyan, green, magenta, red and blue to black. You will find that the colours are arranged in decreasing order of luminance.

The line waveform for this test signal (all visible lines will be the same) takes the shape of Fig. 6. The by-now-familiar line sync pulse and colour burst will be recognised at the start. The luminance modulation is shown as a thick line, and indicates that with monochrome reception the eight stripes would pass from white to black in progressively darker shades of grey. The chrominance modulation (corresponding to full amplitude 95% saturated primary and complementary colours) "rides on the back" of the luminance and consists of a sequence of equal periods of 4.43 Mc/s oscillation with different

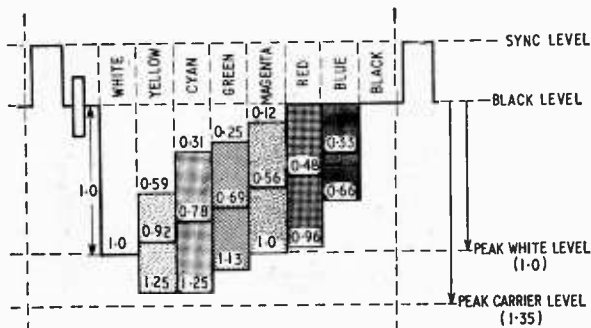

Fig. 6. Diagram showing colour-bar test waveform (for full amplitude 95% saturated primary and complementary colours). Heavy contour shows how signal would be reproduced ideally on a monochrome receiver in bands of progressively darker shades of grey from white to black.

phase angles relative to the reference burst. These are shown as shaded bands centred on the corresponding luminance amplitude levels. The mean luminance amplitude level in any coloured band remains virtually unchanged, but the peak total modulation increases. It should be noted that in the yellow, cyan and green bands the peak carrier amplitude extends down beyond the peak white carrier amplitude limit.

For most purposes, the luminance component of the colour signal can be taken as identical with the black and white signal, although strictly speaking, except for white or shades of grey colours, this is not quite true.

Reception of colour signals in monochrome

Despite the care with which the carrier frequencies for luminance, chrominance and sound are selected to reduce

crosstalk between the signals, certain spurious effects can arise when colour signals are reproduced in black and white on a monochrome receiver.

The most significant spurious effect is the presence of a regular pattern of dots caused by the presence of the colour subcarrier signals. This interference pattern is most obvious in areas of strongly saturated colour in the transmitted picture. The subcarrier also produces additional luminance in such areas owing to the non-linear law of the monochrome display tube.

Another effect observed on colour transmissions reproduced on monochrome receivers arises from the colour burst. This burst, occurring during the post-line synchronizing period, usually forms part of the line flyback period of a monochrome receiver, and thus the subcarrier dots due to the burst are stretched out by the relatively fast retrace scan. This may result in vertical lines or bands down the left hand side of the picture.

The sound carrier may also give rise to spurious picture effects. It forms a beat signal of 1.57 Mc/s with the chrominance carrier and this can give rise to further visible dot patterns.

Further details of B.B.C. colour transmissions

Within the bounds of this article it has been possible only to touch on the main features of the colour television signal. Anyone interested in the more precise technical details should obtain from the Engineering Information Department, B.B.C., Broadcasting House, London, W.1, copies of (a) Information Sheet 4202, "Colour Television," (b) Information Sheet 4002, "625-line Vision Signal Waveform," and (c) Engineering Press Statement 760 "Experimental Colour Television Transmissions."

TV Camera with Solid-State Image Sensing

A FIRST step has been taken towards "a new era of personal TV communication systems" according to RCA, who have just announced delivery of an experimental tubeless television camera, smaller than a man's hand, to the U.S. Air-Force Avionics Laboratory at Dayton, Ohio. The camera's solid-state photoconductive image sensing panel and associated scanning generators have been made by thin-film technology and are the latest outcome of a long-term programme of work in this field by an RCA Laboratories team led by Dr. Paul K. Weimer.* The panel has 32,400 photoconductive elements, deposited on a glass slide, which are scanned by pulse signals applied to a matrix of X and Y thin metal conductors—there being an element deposited at each X-Y intersection. Presumably there are 180 X-conductors and 180 Y-conductors.

An image focused on this array causes each photoconductive element to experience a fall in resistance proportional to the intensity of light falling on it. Orthogonal scanning of the resistance pattern, using the X and Y conductors, then results in a sequence of voltages corresponding to the successive values of the video signal produced by a conventional television camera. Since the process of scanning the resistance (light) pattern is similar to the read-out of digital data

from a computer matrix store, it would be possible to send pictures from the camera directly to a computer for processing or storage.

The image sensing panel is scanned—60 times per second—by two sets of circuits, each containing 540 thin-film transistors (and other components) deposited on a glass slide. On one side the output transistors are connected to the X-conductors of the image panel and on the other side the output transistors are connected to the Y-conductors. The actual scanning circuitry used is not disclosed, but in the earlier work it was based on shift registers which generated pulses in sequence along a line of output terminals connected to the X and Y conductors. A fourth glass slide in the camera carries thin-film circuitry performing various control functions.

Pictures produced by the camera can be sent directly to a television receiver by a miniature microwave radio transmitter, also developed by RCA. This uses conventional transistors.

At present the resolution, sensitivity and speed of response of the solid-state camera are inferior to those of a conventional television camera, but Dr. Weimer says that his team expects to overcome these limitations in the future by the use of new circuit techniques and by the development of image sensing arrays with 10 times the number of photoconductive elements used in the experimental model.

* See, for example, "Integrated Circuits Incorporating Thin-Film Active and Passive Elements" by P. K. Weimer, H. Borkan, G. Sadasiv, L. Meray-Horvath, and F. V. Shallcross, *Proc I.E.E.E.* December 1964. Also a note in *W.W.*, July 1965, p. 350.

CINE FILMING TELEVISION

MODIFYING A 16-MM PROJECTOR TO RECORD VISION AND SOUND FROM A DOMESTIC TV SET

BY J. M. HALE, Ph.D., B.Sc.(Eng.), Grad. I.E.E.

THERE is little doubt that a machine for recording television programmes would form a worthwhile addition to the present-day range of domestic electronic equipment. The video tape recorder appears to be the most attractive solution, but at present the achievement of acceptable performance from reasonably inexpensive equipment still seems some way ahead.

Meanwhile, the availability of magnetically "striped" film stock enables a satisfactory film telerecorder to be made at a reasonable cost and employing well established techniques. The construction of such a recorder using a modified cine projector is described in this article.

Choice of film gauge.—In the interests of low running costs the film gauge should be as small as possible consistent with obtaining acceptable results. To avoid undue loss of picture quality the resolution of the film and optical system should be rather better than that of the television system. If we consider a television picture consisting of horizontal black lines on a white background, the 405-line system is capable of displaying a maximum of about 190 lines. Taking the frame height of 16-mm film as 7.5 mm, the film resolution required is better than 25 lines per mm. It is difficult to be too precise about film and lens resolutions, but this is the sort of figure that one might reasonably hope to achieve quite comfortably in practice.

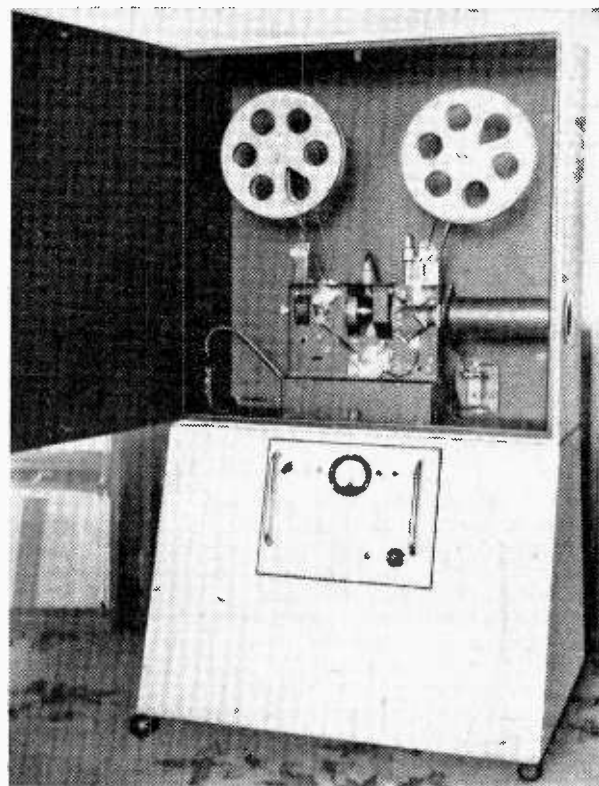

The complete telerecorder in its light-proof cabinet, showing the amplifier mounted in the trolley.

The attractiveness of 8-mm film from the point of view of low running costs and compatibility with other domestic cine equipment is marred by the practice of exposing and processing this gauge in the form of 16-mm (double-8) and slitting it to 8mm before projection. This means that striped single-8 film and facilities for processing it are not normally available.

In addition to the technical difficulties with this gauge, 8-mm projectors with sound are decidedly expensive whereas surplus 16-mm machines are available quite cheaply.

Bearing these factors in mind, it was decided to opt for the 16-mm gauge.

Choice of exposure system.—Having decided on the film gauge, it is then necessary to select a suitable exposure system. There are a number of possible systems for recording television on film, but the one which appears most attractive is the $16\frac{1}{2}$ frames per second system. This was developed by the B.B.C. and described in *Wireless World* in 1949.¹ The exposure cycle for this system is shown in Fig. 1. The film is first exposed to an even and an odd field. It is shuttered during the next even field, during which time the film is pulled down. The next odd and even fields are then photographed and the film is shuttered and pulled down during the next odd field and so on. Each exposed television frame on the film, therefore, consists of a complete television picture, there being $16\frac{1}{2}$ such pictures per second.

This system has a number of advantages for the present application. First, it is a slow pull-down system, the requirements of which can be met by the claw mechanism

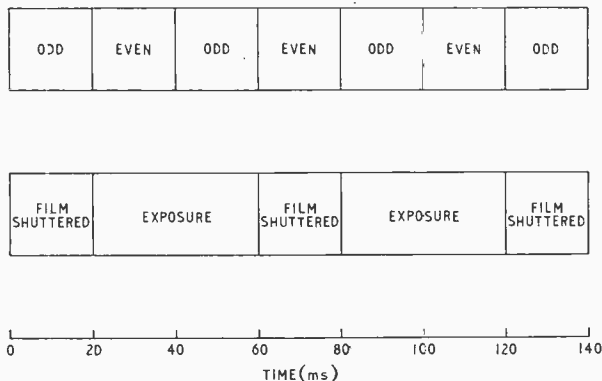
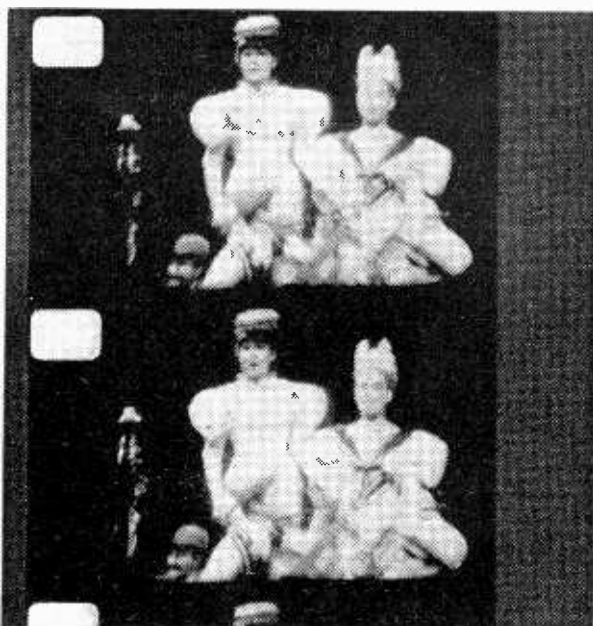

Fig. 1. Cycle of exposure of film to television fields, to give $16\frac{1}{2}$ film frames (complete television pictures) per second.



Frames from a recording, showing sound stripe on the right.

of a standard projector. The use of $16\frac{2}{3}$ frames per second rather than 24 which is usual for sound films results in economical use of the film stock while the film speed of 5 inches per second is sufficiently high for good quality sound recording. The film can be replayed on a standard magnetic sound projector running at 16 frames per second and using a three-bladed shutter.

Modifications to projector.—There are two reasons why the recording machine must be based on a projector rather than on a camera. First, the provision of a constant speed sound loop which is required for synchronous sound and vision recording is a feature peculiar to projectors. Also the pull-down must not occupy more than one third of the total exposure cycle. This is a condition which is satisfied in most projectors but is unusual in cameras.

The projector chosen was a Gaumont British L516. This machine is available cheaply on the surplus market and the form of its construction makes it ideal for modification. The author also uses one which has been modified for magnetic sound as the replay machine. The required modifications for the recording machine may be placed under four headings: removal of parts of the machine not required after modification; provision of a new shutter; fitting of a synchronous motor drive; and fitting of record and erase heads.

Only the basic projector mechanism has to be retained. Redundant items include the carrying case, the lamp house, the optical sound focusing unit, the motor-blower and its control gear and all the amplifier wiring.

The shutter in the recording machine has to operate between the film and the television screen, whereas originally it is sited between the film and the projector lamp. The main projector shaft has, therefore, to be extended through the front of the machine to take the new shutter, and a hole was drilled in the front plate to allow the shaft to protrude. The machine was dismantled, the clutch mechanism was removed and the original shaft was replaced by a 13-inch length of $\frac{1}{8}$ -inch

diameter silver steel. To secure additional mechanical smoothing, a flywheel was mounted on the shaft in the position formerly occupied by the lamp house. The shutter assembly was dismantled and put on one side for use with the new shutter. With the $16\frac{2}{3}$ frames per second system, the shutter has a single opaque sector of 120° and is transparent for the remaining 240° . Such an unsymmetrical shutter would set up too much vibration if it were made out of metal in the conventional way. For this reason, the shutter was made from a 5-inch diameter Perspex disc with a 120° black painted sector. The disc was bored out to fit the original shutter assembly. In the finished machine, the shutter rotates just in front of the projection lens.

To provide the 1,000 r.p.m. drive to the projector shaft, a 1,500 r.p.m. synchronous motor was bolted to the main chassis and coupled to the projector shaft via a toothed belt drive giving a 3:2 step down ratio. The particular motor used was rated at 1/75 h.p. which was more than adequate for the job.

To preserve the standard 28 frame sound-to-picture separation, the magnetic recording head has to be mounted at the point occupied by the optical sound focusing unit on the original machine. A number of mounting arrangements were tried but the one finally adopted was the simplest. The head was bolted on the main plate of the machine with two screws. A rib of metal on the back of the head enables azimuth adjustment to be made by differentially tightening these screws. Positional adjustment is facilitated by having large clearances between the fixing screws and the holes in the fixing lugs of the head. Correct positioning of the head is critical, because of the unfavourable wrap angle inherent in this arrangement where the magnetic stripe is on the convex side of the film. The flexibility in the system is provided by the film, which can bend under the pressure of the head as it is not supported

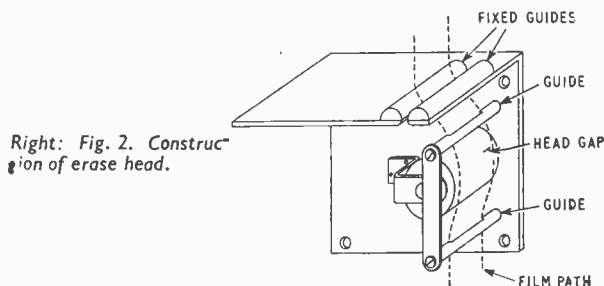

Right: Fig. 2. Construction of erase head.

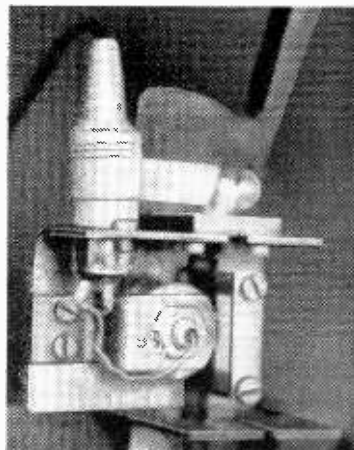

Left: The erase head mounted on the projector.

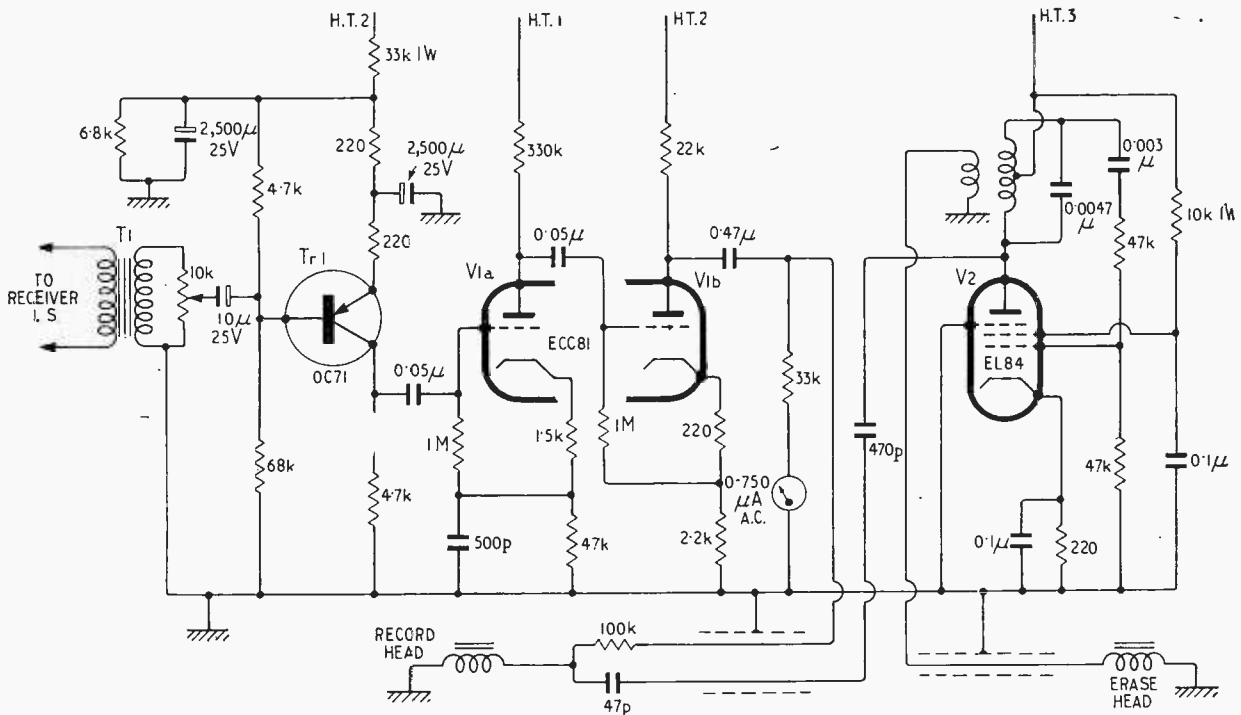

Fig. 3. (Above) Amplifier circuit for sound recording, with (right) the power supply and control unit.

by the sound drum in the region of the stripe. The recording head used was a Reuter bottom track head obtained from the surplus market.

The obvious place to mount the erase head is immediately above the entry rollers. The main problem here is that if the erase head assembly is not to foul the largest spools, there is not much room to get everything in. After one or two attempts, the design adopted was as shown in Fig. 2. All parts were made from scrap metal. The two main guides were formed by filing 16-mm wide slots in 1/4-inch diameter steel rod. The entry guides were filed into suitable shapes from steel strip material. All the guides were case hardened.

Light-proof box and trolley.—It was required that the recorder should be suitable for use with a conventional television receiver. Accordingly, the machine was built as a self-contained unit, the only connection between it and the receiver being a lead carrying the sound signal from the loudspeaker terminals. The projector is housed in a light-proof box which is mounted on a trolley containing the amplifier and control circuitry.

The light-proof box was made from seven-ply plywood and measures 30in×30in×12in. With these dimensions, no limitation on spool size is imposed by

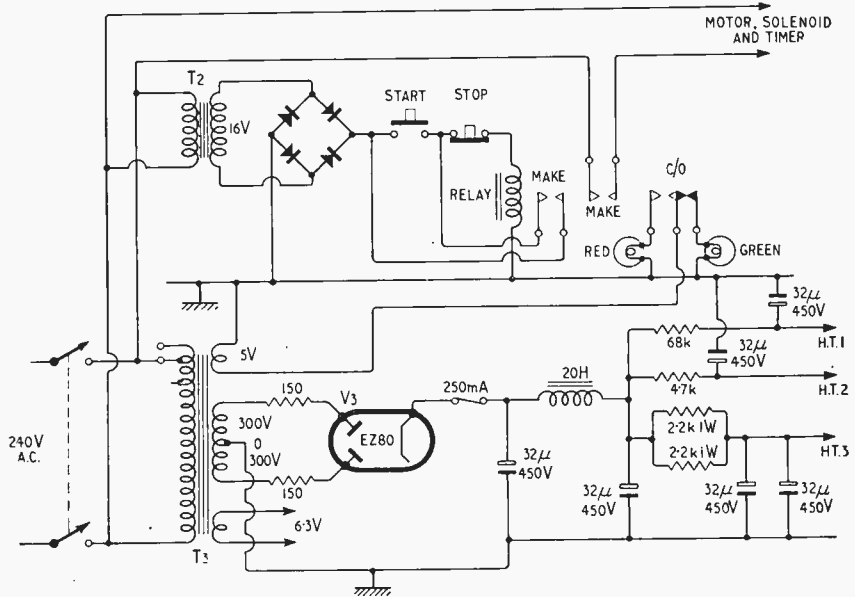

the box. The whole of one side of the box forms the door. When closed, the door is held by four bolts against a wooden fillet which runs round the inside of the box. The inside of the box is painted matt black to absorb any light that does get in. The optical connection between the lens and the outside of the box is made by a 3-inch diameter brass tube mounted in the front surface of the box. This is stopped down at the projector end to about 1 1/2 inch diameter by an annular brass ring soldered into the end of the tube. The required diameter of the tube is a function of the focal length of

the projector lens, three inches being suitable for a 50-mm lens. For shorter focal lengths, the machine has to stand closer to the set and the tube diameter would have to be increased correspondingly.

The trolley was constructed using square section hardwood for the framework and hardboard for the surfacing. To give the whole machine stability, the trolley was made wider at the bottom (24in) than at the top (12in). It was fitted with castors and also retractable rubber feet which can be screwed down to take the weight of the machine off the castors and so prevent it from moving. The height of the trolley was chosen to bring the optical axis of the projector in line with the centre of the television screen.

Amplifier and control circuitry.—The amplifier chassis fits into an aperture in the sloping surface of the trolley, immediately below the door on the box. The complexity or otherwise of this unit is really a matter of personal preference. The techniques for recording on the magnetic stripe from the circuit design point of view do not differ appreciably from conventional tape recording practice. The circuit diagram of the unit used by the author is shown in Fig. 3. Tr 1 is a straight amplifier. V1 (a) provides top lift by frequency dependent degeneration in its cathode circuit. V1 (b) is the output stage and V2 is the bias and erase oscillator. One or two points might be noted. T_1 is necessary to provide isolation from the live chassis of the television receiver. The sensitivity of the amplifier is about 100 mV for full stripe modulation, which is approximately the voltage across a 3-ohm speaker at normal listening levels. To mini-

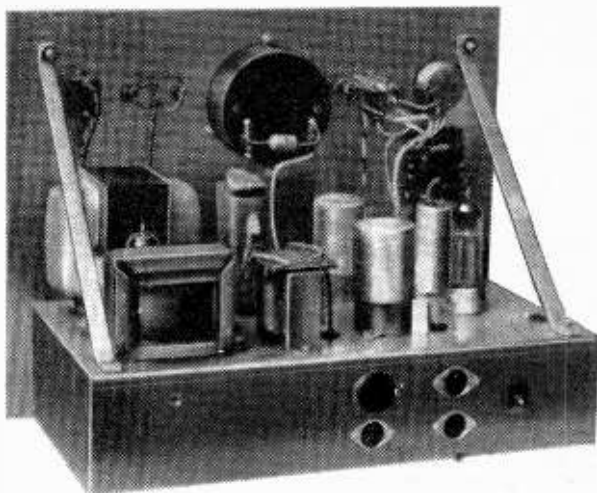

Rear of amplifier chassis.

mize attenuation of the high audio frequencies due to the capacitance of the interconnecting cable, the network for mixing the bias and audio signals is mounted on the projector. No significance should be attached to the range of the signal level meter; it was used because it was available. As shown on the diagram, the motor is controlled by a push-button operated relay.

Setting-up procedures.—The testing of the sound recording channel does not involve techniques which are different in principle from those applying to conventional magnetic recording and will not be further discussed.

A point that must not be overlooked is the phasing of the claw mechanism with respect to the shutter, which must mask the lens during the whole of the pull-down period.

To adjust the focusing of the projector, a scrap length of processed 16-mm film is put in the gate with the emulsion side facing the lens. Using a temporary light source, an image of the film is displayed on the surface of the television tube. The position of the machine is then adjusted until the picture completely fills the screen. The framing knob on the projector provides a certain amount of up and down adjustment. Focusing is then adjusted to give as sharp a picture as possible on the screen. By dismantling the focusing assembly and replacing it with a set screw, it is possible to lock the focusing. This adjustment only has to be done once. Thereafter, it is a matter of positioning the machine so that it is squarely facing the television screen and is the correct distance away from it.

Loading the machine with film in total darkness is an interesting exercise. One has to ensure that the film is the right way round with the emulsion, stripe and sprocket holes where they should be. After lacing up has been completed, the film is inched through the machine making sure that the loops are adequate and that the film is securely in the gate. When it is felt (literally) that everything is in order, the door is shut and secured by the fixing bolts.

Rangefinder, shutter and timer.—One or two items which make the machine easier to use will now be described. When setting up the machine for recording, it is possible to position it with the aid of a tape measure.

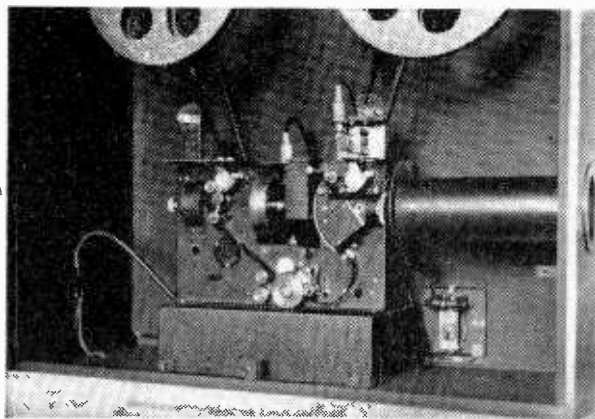

Details of projector mechanism.

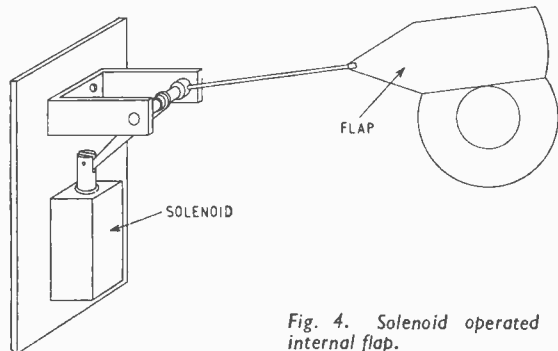

Fig. 4. Solenoid operated internal flap.

Care must be taken to ensure that it is pointing directly at the television screen. If the machine has to be moved out of the way when it is not in use, this setting-up procedure can become tiresome. By the use of a split-image rangefinder mounted on the top of the box, the machine can be moved quickly into position.

When the machine is not in use, light is kept out of the box by an external flap which covers the end of the brass tube. Although it is possible to remove the flap at the same time as starting the machine, this is rather cumbersome. For this reason, a solenoid operated internal flap was also fitted. This covers the other end of the brass tube when the machine is at rest. The solenoid is connected in parallel with the motor and uncovers the end of the tube while the motor is running. The arrangement is shown in Fig. 4.

When making a number of short exposures on a long film, it is desirable to know at any time how much film remains to be exposed. As an alternative to using a stop-watch and keeping notes, it is convenient to mount on the machine an electric timer which is wired in parallel with the motor. By setting the timer after loading the

film, one can always see at a glance how much recording time remains.

Operational experience.—Results obtained during the short time for which the machine has been in operation have been quite encouraging. Initial exposures were made on Tri-X reversal film (about 200 A.S.A.) which proved rather too fast. It is possible to reduce the exposure by placing a piece of card with a hole in it in front of the lens. By stopping down by two stops, satisfactory exposures were obtained. More recently, Plus-X reversal film has been used which is more suitable as it is slower and has a finer grain structure. As always with cine work, running costs are high. With professional processing, it works out at about 15 shillings per minute. The cost of the whole machine was about £70, although no doubt this figure could be improved upon by adopting a less elaborate design.

REFERENCE

"Television Recording," by D. A. Smith, *Wireless World*, August 1949, pp. 305-306.

TONE-OPERATED SWITCH

USING SIMPLE TWIN-T TUNED A.F. CIRCUIT

THE circuit shown may be used for applications requiring remote control by a direct sound link, or by modulated ultrasound or light. The circuit is frequency selective, being tuned to about 800 c/s, but other frequencies can be used, provided the twin-T components are altered. Selectivity is provided by a twin-T filter included in a feedback loop. Bootstrapping is used to increase first stage voltage gain, thus giving good Q . The output of the tuned amplifier is rectified and the d.c. component used to actuate a relay. The diode across the relay winding prevents the back e.m.f. from damaging the transistor.

The centre frequency may be altered by changing the twin-T components values according to $f = 1/2\pi RC$ but two resistors (3.9k Ω in the diagram) are restricted to

values between 1.8k Ω and 8.2k Ω . For frequencies below 100 c/s the values of coupling and decoupling capacitors must be increased. The rectifier smoothing capacitor may be chosen to give an operating delay, this being about 0.5 s in the circuit shown. A delay can give some protection against accidental operation by stray tones.

The relay resistance must be greater than 100 Ω , 700 Ω being used in the prototype, and should pull in with 6 V across it. The emitter resistor is given a value of 1/20th of the coil resistance.

Sensitivity can be increased by reduction of the 4.7k Ω series resistor at the input, this being included in the original to prevent input impedance falling too low when a number of units were connected in parallel. T. E. E.

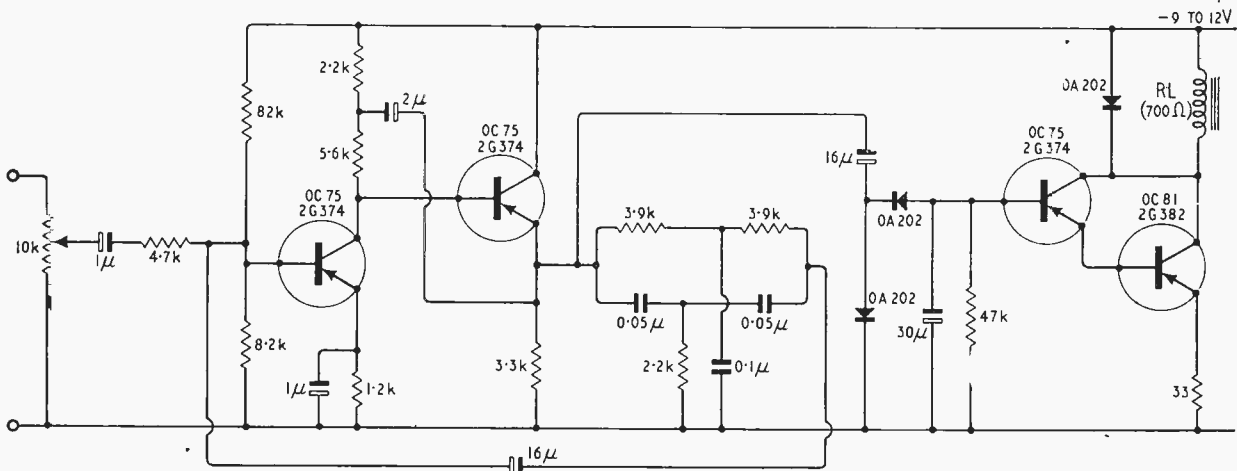

WORLD OF WIRELESS

B.B.C. Men Criticize TV Set Sound Quality

TELEVISION receiver sound reproduction came in for a heavy verbal beating from music critics and B.B.C. music programme producers at a recent seminar on music in television held at the B.B.C. Television Centre, London.

Representing B.R.E.M.A., the set makers' trade association, Mr. M. A. E. Butler said that the manufacturers tried to provide as good sound reproduction as the "cut-throat" market conditions allowed. The recent trend of forward-facing loudspeakers was one improvement. However, he felt that the public was not greatly concerned about the receiver sound channel—picture deficiencies were much more of a problem—and in fact his association had not received any complaints about sound reproduction. A senior B.B.C. television sound engineer then remarked angrily that if the set makers had not received any complaints the B.B.C. certainly had; in fact, the B.B.C. was being unjustly blamed for the poor sound quality. In music programmes much of the

potential enjoyment was in the sound, over which the B.B.C. took a great deal of trouble, but full enjoyment was being denied to the television audience. People simply did not realize how much they were missing because of the deficiencies of their receivers. (Many of the critics present said they used separate television sound tuners and sound reproduction equipment.)

Asked about the possibility of stereophonic sound for television Mr. Butler said he did not consider this an idea worth pursuing and, indeed, he did not see a very big future for stereo on the f.m. sound service.

Humphrey Burton, head of B.B.C. music and arts TV programmes, asked Mr. Butler to convey the criticisms that had been expressed to B.R.E.M.A., in the hope that receivers might be improved in the future. Mr. Butler seemed relieved to escape from a somewhat hostile situation—understandably, for the manufacturers' case was not a very convincing one.

A.A. Radio-telephone Service

ON December 1st the Automobile Association opened their Linkline radio network covering the London-Birmingham section of the M1. This 24-hour service is intended to provide two-way speech communication between the A.A. operations rooms in London and Birmingham and individual motorists. With the six channels at present in use the A.A. estimate that they could cope with 200 users in the area shown on the map.

The transmissions on about 160 Mc/s are spaced 12.5 kc/s apart. The fixed station transmitters, supplied and installed by Pye Telecommunications Ltd., are rated at 25 W r.f. power. The remote stations are linked by G.P.O. landlines to their

| Station No. | Position | Control Centre | Linkline Channel | Frequency (Mc/s) | |
|-------------|----------------|----------------|------------------|------------------|----------|
| | | | | Tx | Rx |
| 1 | Hampstead | London | 4 | 160.00 | 164.5 |
| 2 | Crystal Palace | | | 159.95 | 164.45 |
| 3 | Caddington | | | 159.95 | 164.45 |
| 4 | Bow Brickhill | Birmingham | 6 | 160.1625 | 164.6625 |
| 5 | Cold Ashby | | | 159.95 | 164.45 |
| 6 | Meriden | | | 159.95 | 164.45 |
| 7 | Romsley | | | 160.00 | 164.5 |
| 8 | Hagley Road. | | | | |

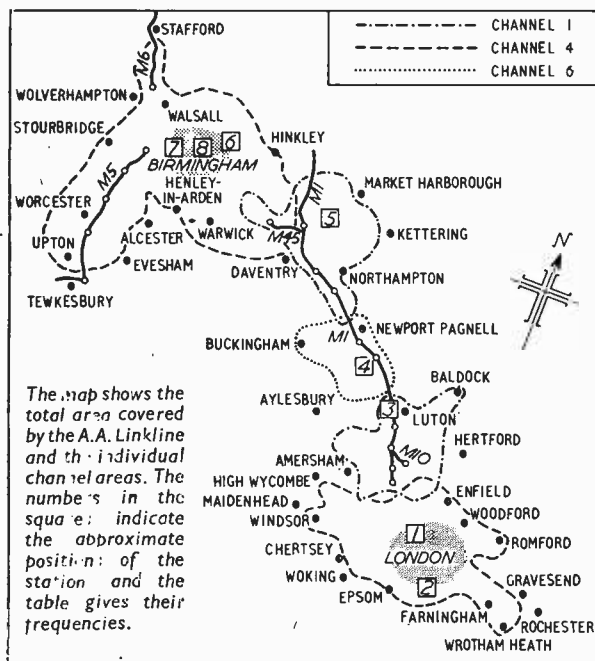

control centres. The rental fee for the car radio-telephone equipment, licence fees, servicing and all radio calls is £180.

Aurorae Studied by Rocket Soundings

PAYLOADS in a series of sounding rocket launchings from the new ESRO range at Kiruna, Northern Sweden, are designed to investigate the effect of aurorae on the physical properties of electrons and ions such as temperature and density. The site is ideal for the study of auroral phenomena since displays occur most frequently at latitudes of 65-70°. Long nights also aid visual observation of auroral phenomena. The rockets will be tracked by radar and slant-range Doppler measurements and trajectory and scientific data will be sent to ESDAC, the ESRO data centre at Darmstadt, Germany.

One of the experiments, a positive ion measuring probe, is sponsored by Professor R. L. F. Boyd, of University College, London. The object is to measure positive ion concentration in the D and E layers of the ionosphere by means of four negatively-biased probes. (In previous launchings of this experiment the rockets did not reach the expected altitude.) Another experiment, sponsored by the Ionosphere Laboratory, Copenhagen, aims to provide information on electron density profiles and collision frequency by passing radio signals of various frequencies to the ground and observing the Faraday rotation. A different technique for electron density profile determination is used in another experiment by the Ionosphere Institute, Breisach, Germany, using an impedance probe in a similar manner to an earlier experiment. Cosmic ray proton flux and far ultra-violet spectra will also be recorded.

Radio Show cancelled

ONCE again the London Radio & Television Show has died in embryo. Plans for the 1967 trade and public show made by Industrial & Trade Fairs, last year's organizers, have been abandoned because of lack of support from the domestic equipment side of the industry.

Some are asking "have we seen the last radio/television show in London or will it now be biennial?" This remains to be seen. However, plans have been made to enlarge the radio communications exhibition sponsored by the R.S.G.B. and we may see some domestic equipment manufacturers taking space at that show which is to be held in one of the Horticultural Society's Halls, Westminster, in September. If so the radio show will have completed a circle, for it was here that the first one was held in 1922!

Communications on tap at home

THE idea that the homes of the future will all have a "communications" supply, laid on with the water, the gas, the electricity and other familiar services, is obviously getting nearer to reality. Mr. Edward Short, the P.M.G., revealed in the House of Commons that the Post Office is already costing a scheme for fitting houses with a single cable that will serve for sound broadcasting, television, telephone, the reading of meters "and so on" (perhaps computing power?). He said it will be tried out in a new town in the near future, but could not give a firm date.

Rugby Refurbished

A DECISION by the Post Office to increase the radiated power, and enhance the capability of the 40-year-old v.l.f. transmitter at Rugby radio station has resulted in a doubling of both radiated power and signalling speed. The Post Office Engineering Department has redesigned and rebuilt this transmitter, which with its famous call-sign GBR is used for world-wide communication with British ships, and for broadcasting Greenwich time signals throughout the day.

The 18 water-cooled valves previously employed have been replaced by three vapour-cooled amplifier valves for use singly or in combination. The modulator circuitry has been redesigned so that frequency shift, as well as c.w. signals can be generated at speeds up to 72 bauds (a speed of 100 bauds was attained during a recent test). The output power from the GBR transmitter, is 450 to 500 kW, and the radiated power is 60 kW at 16 kc/s (18,750 metres). With carrier frequency stability of 5 parts in 10^{10} (and an eventual stability of 1 part in 10^{10} when an atomic frequency standard such as a rubidium gas-cell is installed), this transmitter resumes its place as an international standard of time and frequency.

I.E.E. New Grades of Membership

CHANGES, foreshadowed some months ago, in the membership structure of the Institution of Electrical Engineers were introduced on December 1st. The new corporate membership structure is now Honorary Fellow (Hon.F.I.E.E.) formerly honorary member, Fellow (F.I.E.E.) formerly member, Member (M.I.E.E.) formerly associate member. A new non-corporate class of Associate Members combining existing graduates and associates has been formed, admission to which is by satisfying the examination regulations. A further new class of non-corporate membership for those interested in "the learned society activities" of the Institution but not eligible for any other class has been introduced and will be known as Associates.

S.D.I. Schemes to be Co-ordinated

LATELY discussions have taken place between representatives of the Royal Society, the Office for Scientific and Technical Information, the National Electronics Research Council, the Institution of Electrical Engineers, the Institution of Elec-

tronic and Radio Engineers and other bodies concerning the co-ordination of existing and projected mechanized information retrieval systems.

On the recommendation of Lord Mountbatten, the chairman of N.E.R.C. and initiator of the Council's project on Selective Dissemination of Information (S.D.I.) it has been agreed that the I.E.E. should administer the scheme in view of the projected information activities of the Institution. This arrangement will allow for the closest co-ordination between the S.D.I. project and the proposed scheme for computer production of *Science Abstracts* by the I.E.E., and subsequently a computer-based information retrieval system.

R.A.E. and University Collaboration.—An agreement has been concluded between the Royal Aircraft Establishment and the University of Southampton for collaboration in teaching, planning and research involving many of the departments in the Faculty of Engineering and Applied Science. A number of scientists from the R.A.E. are to be co-opted to the University staff and receive honorary titles.

R.I.C.-B.R.E.M.A. Merger?—With the retirement of Mr. R. Kelf-Cohen, director and secretary of the Radio Industry Council the council is moving on January 1st to the headquarters of the British Radio Equipment Manufacturers' Association at 49 Russell Square, London, W.C.1. Mr. Sydney E. Allchurch is to combine his present duties as director of B.R.E.M.A. with those of director and secretary of the R.I.C.

Mullard Gold Medal.—Professor P. M. S. Blackett, the president, announced at the anniversary meeting of the Royal Society that Mullard had provided a capital sum of £20,000 to provide each year a gold medal "for achievements directly relevant to the progress of the British economy." The recipient of the medal, to be awarded for the first time next November, will also receive £1,000.

Bournemouth College of Technology is starting two 20-week part-time day and evening courses on colour television servicing in January. Each course, which meets the requirements for the City & Guild and R.T.E.B. examination, will consist of 7½ hours study per week (one afternoon and one evening). The fee is £2 4s.

A course of nine lectures on **Television Systems** will be given in the Department of Electrical Engineering of the University of Aston, Birmingham, on Thursday mornings commencing on January 19th. The syllabus will include design, installation and servicing of television receivers (including colour), camera and studio equipment, transmitter design and international standards.

"Operational Weather Satellites."—The transmission frequencies of NIMBUS 2 and ESSA 2 were unfortunately transposed on p. 592 of the December issue. NIMBUS radiates on 136.95 Mc/s and ESSA on 137.5 Mc/s. Also the number of turns for the helix receiving aerial was not given; it is eight.

"Guide to Broadcasting Stations"

OPERATING frequencies and power of all authorized and unauthorized long- and medium-wave broadcasting stations in Europe are given in the fifteenth edition of "Guide to Broadcasting Stations". Stations are listed both geographically and in order of frequency. In the lists covering the world's short-wave transmitters there are nearly 4,000 entries.

New to this edition are the sections devoted to a selection of the more powerful European television and v.h.f. sound broadcasting stations. In both of these lists all British stations are included. The information on the television stations includes the standard used by each country.

The 136-page book was compiled by the staff of *Wireless World* from information received from various sources and checked against the B.B.C.'s Tatsfield station's measurements and E.B.U. lists. It costs 6s (postage 9d).

PERSONALITIES

J. A. Ratcliffe, C.B., C.B.E., F.R.S., formerly director of the Science Research Council's Radio and Space Research Station at Slough, has received one of the Royal Society's three Royal Medals for the current year "for his distinguished studies in the ionosphere and on the propagation of radio waves." Mr. Ratcliffe, who is this year's president of the I.E.E., recently received the Institution's Faraday Medal.

P. H. Spagnoletti, O.B.E., B.A., M.I.E.E., director of business development for Standard Telephones and Cables Ltd., has succeeded **J. Bell, B.Sc., F.Inst.P.**, as chairman of the Electronic Valve and Semi-Conductor Manufacturers' Association. Mr. Bell, who had not completed his term of office as chairman of VASCA, resigned because he recently relinquished his position as managing director of the M-O Valve Company and has become managing director of the aerospace and defence division of G.E.C. (Electronics) Ltd.

Edmund E. Webster, M.I.E.R.E., formerly group director of the Components Group of the Plessey Company, has become managing director of the Cambridge Instrument Company Ltd. in succession to the joint managing directors, **L. F. Cooke** and **W. E. Lamb**, who are both nearing retirement age. Mr. Cooke and Mr. Lamb remain directors. Mr. Webster, who is 57, started his career with Marconi Marine and after war service in the Air and Supply Ministries joined Plessey in 1950 as chief inspector of the Swindon region.

John Spencer Wills, who has been chairman and managing director of Rediffusion Ltd. since 1947, has relinquished the managing directorship but remains as chairman. **Paul Adorian, F.C.G.I., M.I.E.E., M.I.E.R.E.**, who joined the company as a development

engineer in 1932, has been appointed managing director. He is also managing director of its associated company, Rediffusion Ltd. Mr. Adorian, who entered the industry as a student engineer with Standard Telephones and Cables, has successively been assistant chief engineer, chief engineer and deputy managing director of Rediffusion Ltd. In 1956 he became a founder director of Associated Rediffusion Ltd., and since that year has been managing director of that company and of its successor, Rediffusion Television Ltd. He is also chairman of Redifon and of Redifon-Astrodata.

Maurice Exwood, M.I.E.R.E., who has become deputy managing director of Rediffusion Ltd., joined the staff of a relay company operating in Nottingham as chief engineer in 1933. Two years later that company became a member of the Rediffusion Group. In 1954 he organized a new company, Rediffusion Vision Ltd., which now manufactures the television receivers rented and sold by Rediffusion. He subsequently became managing director, and is now also chairman, of that company and on the boards of a number of other companies in the group.

T. A. Cross, M.I.E.R.E., managing director of Redifon Ltd. for the past four years, has been appointed to the board of Rediffusion Ltd. which he joined as a linesman in 1929. He was manager and chief engineer of the South Wales Rediffusion Service Company at the age of 24. In 1946 Mr. Cross was appointed general manager and chief engineer of the Rediffusion operation in Trinidad, where he was responsible for setting up Radio Trinidad and re-organizing the wired distribution service on the island. In 1953 he went to Canada and until 1962 he was the senior executive of the Rediffusion Group in Canada.

Professor Emrys Williams, B.Eng., Ph.D., M.I.E.E., has been elected president of the Institution of Electronic & Radio Engineers for 1967. A graduate of Liverpool University, he received his doctorate for research in electro-acoustics, and after a few years in the Research Laboratories of the G.E.C. started his academic career in 1937 at Kings College, Newcastle-upon-Tyne. Ten years later he was appointed to the chair of electrical engineering at the University College of N. Wales, Bangor. Since 1954 he has occupied the first chair of electrical engineering at the University College of South Wales and Monmouthshire in Cardiff.

Robert C. G. Williams, Ph.D., B.Sc. (Eng.), D.I.C., A.C.G.I., M.I.E.E., chief engineer of Philips Electronic & Associated Industries Ltd., has been appointed chairman of the council of the Institution of Electrical and Electronics Technicians Engineers.

Bernard J. O'Kane, Ph.D., B.Eng., A.M.I.E.E., general manager (electronics) of the Marconi Company, is the 1966/67 president of the European Organization for Civil Aviation Electronics (EUROCAE). Dr. O'Kane was one of the architects of this organization, which was formed in 1963 to provide a co-ordinating body for European manufacturers and users of aviation electronics, and he has been chairman of the steering committee since its inception. Dr. O'Kane, who is 54 and a graduate of Liverpool University, was on the staff of the G.E.C. Research Laboratories from 1931 to 1947 although he was seconded to the Telecommunications Research Establishment at Malvern for the major part of the war. In 1947 he became chief engineer of International Aeradio Ltd., and five years later he joined the Marconi Company as chief air radio engineer. In 1965 he was appointed to his present position.



Paul Adorian



Maurice Exwood



T. A. Cross



Dr. B. J. O'Kane

Eric Wolfendale, B.Sc.(Eng.), M.I.E.E., has been appointed deputy managing director of Racal Research Ltd. He was formerly technical director of the company. Mr. Wolfendale was head of the Mullard Semiconductor Measurement and Application Laboratory at Southampton until 1962, when he went to Kenya to join the staff of the Royal College, Nairobi. He returned to the U.K. to join Racal last year.

John G. Scott, B.Sc., A.M.I.E.E., has been appointed to the board of Electro-sil Ltd., of Sunderland, as technical director. He joined the company in June as engineering manager, having previously been technical manager of Hughes International (U.K.) Ltd. A graduate of St. Andrew's University he was for nine years with Ferranti Ltd., Edinburgh, where he worked on the development of advanced airborne radar systems.

J. M. Carson has rejoined the Marconi International Marine Company as acoustical consultant to its Elettra Sound Systems division, which will shortly be leaving the Marconi Marine headquarters at Chelmsford to occupy separate premises some ten miles away at The Causeway, Maldon, Essex. Mr. Carson began his career with Marconi Marine and was a seagoing radio officer for nine years until 1927 when he joined the staff of the Radio Technical College, Hammersmith, as senior lecturer. He later entered the film industry in which he has since specialized in architectural acoustics and electro-acoustical engineering.

L. W. Owers, Grad.I.E.R.E., has been appointed manager of the Mullard Education Service, in succession to **K. E. J. Bowden** who has left the company to join the staff at the Northern Polytechnic, London. Mr. Owers was previously a training engineer with Taylor Instrument Companies (Europe) Ltd. and before that was an instructor at the R.E.M.E. School of Electronic Engineering at Aborfield, Berks.

Philip A. L. Harris, B.Sc., A.M.I.E.E., has been appointed marketing manager of S.T.C. Semiconductors Ltd., of Footscray, Kent, the company formed earlier in 1966 to integrate the various semiconductor interests of Standard Telephones and Cables. He recently joined the company from the Industrial Markets Division of Mullard Ltd., where he was responsible for marketing components to the computer industry.

H. Andrewes, O.B.E., M.I.E.E., who in 1964 retired from the Dubilier Condenser Company where he was for many years in charge of the Technical Sales Department, is now acting as a consulting engineer. His home address is 18 Sheldon Avenue, Highgate, London, N.6.

F. D. Roberts, B.Sc., A.M.I.E.E., was recently appointed to the board of Coubro & Scrutton (Holdings) Ltd., and will be responsible for technical policy and management of the group, which includes Associated Aerials Ltd., A. N. Clark, Ltd. (who specialize in telescopic masts) and R.T. Masts Ltd. He becomes managing-director of Coubro &



F. D. Roberts

Scrutton Ltd., and joins the board of directors of the other members of the group. Mr. Roberts entered industry as a graduate trainee with S.T.C. and spent ten years at their New Southgate works before joining Coubro & Scrutton Ltd.

Keith E. Harris, and **Desmond A. Malden**, Grad.I.E.R.E., were recently appointed to the board of directors of Keyswitch Relays Ltd. Mr. Harris joined Keyswitch in 1961 and was appointed sales manager the following year. He was at one time a technical officer in the Post Office Engineering Department and later in the telecommunications department of Beaverbrook Newspapers. Mr. Malden joined Keyswitch as technical manager in 1960, also from the telecommunications department of Beaverbrook Newspapers. He was a radio officer with the International Marine Radio Company during the war, after which he was appointed resident engineer in Bombay.

Five radio physicists and engineers are among 29 Government research scientists who have recently been awarded "special merit" promotion. The object of the promotions—"to grades which are broadly comparable to the rank of university professor or reader"—is to allow the scientists to continue their research work without the administrative responsibility normally associated with their new grades. The recipients are:—

J. S. Hey, M.B.E., D.Sc., who is promoted to chief scientific officer. After graduating in physics at Manchester University he joined the Army Operational Research Group of which he became head. In 1952 he joined the Royal Radar Establishment and devised the first large radio-telescope in this

country capable of operating down to centimetric wavelengths.

G. F. Clarke, O.B.E., B.Sc., who graduated at Birmingham and spent ten years in electronic research in industry before joining the Scientific Civil Service in the then Air Defence Experimental Establishment in 1938, is promoted to deputy chief scientific officer. During the war he worked initially on Army radar and then the problems of control and guidance of guided weapons. Since the end of the war he has been at R.A.E., Farnborough.

Elizabeth A. Killick, B.Sc., of the Admiralty Surface Weapons Establishment, who works on microwave aerials for radar and radio, is promoted senior principal scientific officer.

W. T. Duerdoth, B.Sc.(Eng.), A.M.I.E.E., and **D. L. Richards**, B.Sc.(Eng.), A.M.I.E.E., of the Post Office Research Station, Dollis Hill, are promoted staff engineers. Mr. Duerdoth was with the team which initially worked on the development of electronic telephone exchanges and more recently has been concerned with integrated switching and transmission systems for digital telephony using p.c.m. Mr. Richards has also been working on pulse code modulation and satellite communication systems.

OBITUARY

Rear-Admiral Sir Philip Clarke, K.B.E., C.B., D.S.O., director of the Naval Electrical Department, Admiralty, from 1951 to 1955, died on November 13th aged 67. Sir Philip, who entered the Royal Navy as a cadet in 1911, was president of the British Institution of Radio Engineers (now I.E.R.E.) from 1954 to 1956.

Eric K. Cole, C.B.E., Hon M.I.E.R.E., who was the founder of the Ekko organization, died on November 18th at the age of 65. Mr. Cole started the company bearing his name in Southend-on-Sea, Essex, in 1922 and was chairman and managing director when it was merged with the Pye organization in 1960. He then became deputy chairman of British Electronics Industries Ltd. the joint holding company. He resigned a year later and in 1962 joined Robinson Rentals as advisory chairman but two years later resigned.

Fritz Langford-Smith, B.Sc., B.E., well-known author of the "Radio Designer's Handbook," has died in Sydney aged 62. He came to England from Australia towards the end of 1956 and became chief of the technical publications department of the English Electric Valve Co. He returned to Australia because of ill health in 1963. Prior to coming to this country, Mr. Langford-Smith, who graduated at Sydney University, was with Amalgamated Wireless (Australasia) from 1932 and was for some time engineer-in-charge of the company's valve laboratory.

NEWS FROM INDUSTRY

ANGLO-PORTUGUESE TELEPHONE LINK

DEEP-SEA solid-state repeaters are to be used with an S.T.C. submarine cable which has been chosen by the Post Office for a telephone link between Great Britain and Portugal. This contract for a 1,000-mile-long telephone cable system is worth £4.25M to Standard Telephones & Cables Ltd. It will be laid between Kennick Sands (near the Lizard in Cornwall) and Sesimbra (20 miles from Lisbon) by the G.P.O. in collaboration with the Companhia Portuguesa Radio Arconi. The best possible speech quality is achieved by the use of special equalization techniques. The solid-state repeaters will be laid at 7½-nautical-mile intervals, 133 of these being required. A total of 480 simultaneous telephone channels (4kc/s) will be carried by the cable. The cable at the shore ends will be heavily armoured type for about 300 miles, the other 700 miles of cable being Post Office Mk. II lightweight 0.99 in. Ten equalizers will be spliced into the cable at various points to achieve optimum transmission quality.

RACAL TO MAKE OWN INTEGRATED CIRCUITS

THE next Racal communications receiver using the Wadley technique, for which the makers are well known, will almost certainly be an integrated-circuit type. The firm are setting up a new group, Racal S.I.C. Division, at their research centre in Tewkesbury, Glos., to investigate the design and manufacture of special i.c.s for use "in the first instance" in communications equipment and digital instrumentation. The idea is to establish, in the current jargon, an "in-house facility" for making the small quantities of special i.c.s that would be uneconomic for semiconductor device manufacturers to produce for them. At the same time Racal expect that they will be using a large proportion of standard i.c.s. They also envisage the future use of large-scale integration in equipment manufacture. Incidentally, Racal Communications Ltd. received during the eight-week period up to 5th December a record of export orders for communications equipment valued at "well over £1M."

U.K. RECEIVER DISTRIBUTION

The graph shows the number of sets distributed by manufacturers over the past three years. The monthly figures were supplied by the British Radio Equipment Manufacturers' Association.

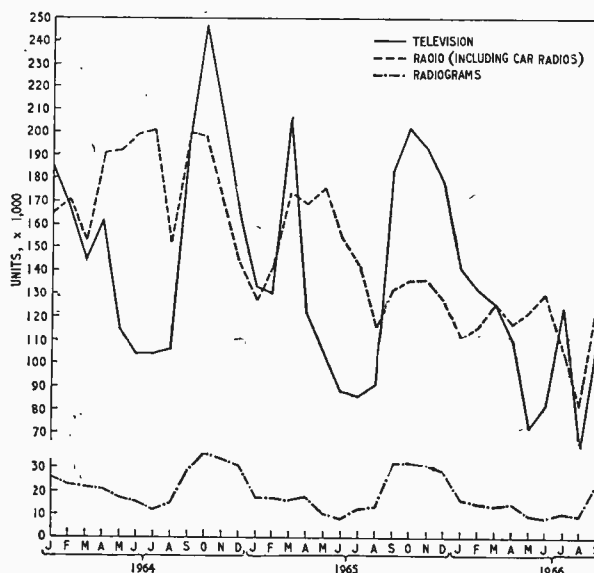

Evaluation of Ferranti military lightweight navigators is to be carried out during their installation in a B.O.A.C. Boeing 707 freighter flying between London and North America. A succession of these navigators will undergo trials so that data relating to systems performance and assessment of their long range ferry capabilities can be obtained. They will provide latitude and longitude readouts only during these trials. The four gimbal, all attitude inertial platform carries single-axis rate integrating floating gyroscopes, and three single-axis, force-feedback accelerometers. Later in 1967, a civil version, the FE 700, and a Ferranti Argus 400 digital computer will be installed in a B.O.A.C. VC-10. This integrated digital inertial navigation system provides the extensive navigation, steering, and fix monitoring information necessary for global operation. After all tests have been concluded both on this and other competitive navigational systems, it is expected that B.O.A.C. will select equipment that will be installed in its jet transport fleet in 1968.

Add-a-Vision, the electronic viewfinder for a 35 mm film camera introduced by the Livingston Group a few months ago (see March 1966 issue, p. 142) is to be produced for 16 mm cameras. An order for the first three production models has been received from A.B.C. Television Network, New York. Add-a-Vision provides not only a 7-in picture for the camera man instead of the small one by the conventional optical viewfinder, but also by display monitors enables the director and producer to watch scenes as they are being shot.

Correction.—Since Racal's advertisement on p. 45 in this issue went to press it has been pointed out that the figure of 10 MHz is quoted instead of "15".

The recently occupied headquarters of the Livingston Group at Greycaines Estate, North Watford, Herts, were officially opened by J. H. H. Merriam, deputy engineer-in-chief of the Post Office, on November 16th. The group, which now consists of nine companies, operates a printed circuit factory in Bognor Regis, a film and recording studio in Barnet and a cabinet factory in Southall in addition to the new headquarters and factory building.

Pocket radiotelephones for ten thousand policemen will be supplied by Pyc Telecommunications Ltd. of Cambridge under a second Home Office contract worth £500,000. Systems using the Pocketfone were installed in London and Glasgow about 18 months ago and have proved satisfactory to both police and Home Office authorities.

Motorola Semiconductor Products Inc. has appointed a second U.K. distributor—Semicomps Ltd., of 78 Stephans Chambers, Bank Close, Hemel Hempstead, Herts (telephone 52318). The company is newly formed and its directors are T. A. Williams and C. M. Yandell. (The other Motorola semiconductor distributor is Celdis Ltd.)

A manufacturing licence agreement has been signed by Photain Controls Ltd., of Leatherhead, Surrey, and Sanken Electric Co. Ltd., of Tokyo, Japan. The agreement will permit Photain Controls to manufacture the Sanken range of solid-state inverters, converters and power supply units. These will be manufactured to a basic design employing U.K. components, and to suit U.K. requirements. The range of inverters and converters has capacities of from 100 VA to 5 kVA. The power supplies vary from 500 mA to 15 A with a range of high and low voltage outputs.

I.Cs in Communications Equipment

USING EXISTING INTEGRATED-CIRCUIT LOGIC UNITS AND OPERATIONAL AMPLIFIERS

By P. J. FORREST,* A.M.I.E.R.E.

Integrated circuit research and development effort has so far been mainly concentrated on the realization of complex digital systems. The techniques evolved permit dramatic improvements in equipment reliability, reduction in volume and reduction in power consumption. Most of all, they allow rigid control of equipment design and repeatability in production. Only recently have attempts been made to apply these circuit techniques to the solution of circuit problems in communications equipments and this article attempts to show how this may be done.

THE basic design requirements of any future communications equipment will be small size and weight, high reliability in severe environments and complex function. These can be realised only by intensive use of silicon integrated and film circuits. The s.i.c. content of such an equipment can be readily broken down into three distinct groups (with a few exceptions):

- Operational amplifiers
- Wide-band amplifiers
- Digital devices.

The principle of the operational amplifier has been widely publicised recently with the advent of s.i.c. versions. Basically it is a d.c. differential-input amplifier with, ideally, infinite input impedance, zero output impedance and infinite bandwidth and gain. Practically, Z_{in} is typically $100k\Omega$, Z_{out} is 100 ohms, bandwidth is 1-10 Mc/s and gain (open-loop) is 70-90 dB.

These amplifiers are offered as single monolithic devices in either TO-5 or flat packages. The circuit functions in which these devices are used are determined by the external feedback conditions applied, so it is necessary to determine the transfer function only—gain being

provided from the device. Amplifiers, filters, oscillators and triggers are all realised using this approach. Many sophisticated devices are now advertised, with equally sophisticated price tags, but it has been found that most circuit requirements can be satisfied by fairly straightforward amplifiers which are easier to handle and comparatively inexpensive'. Applications will be given later.

The wide-band amplifiers² are employed in i.f. strips, and have bandwidths of typically 10-90 Mc/s. Each monolithic chip gives about 25 dB-30 dB of current gain and has a built-in a.g.c. facility.

Digital devices can be introduced to realise some functions that would otherwise require discrete linear components. This approach takes maximum advantage of the high packing density attainable and eliminates many of the problems inherent in linear circuit design. The complexity of the circuitry is increased, but the control of the design is simplified, as is the physical and mechanical design of the resulting hardware.

Several factors influence the construction of the equipment. High reliability dictates, among other things, the reduction to a minimum of interconnections and moving parts (including fans, relays, mechanical controls and moving tunable elements).

Discrete components, to be compatible with the s.i.c.s, need to be not only as small as possible, but of minimum practicable height. This indicates the use of film circuits, and, at the moment, screen printing of resistors and interconnections allows the highest packing density (in a ratio of about 4:1 to that given by evaporated films). Ceramic (alumina) is at present the best material for the basic substrate, permitting screen printing of resistors and interconnections and (see Fig. 1) the mounting of the s.i.c.s. As well as being a good electrical insulator, it has comparatively good heat conducting properties, approaching those of metals. It is comparatively cheap, can take circuits on both sides with the provision of through-holes and is readily available.

The s.i.c.s are, ideally, mounted in flat packs. The equipment circuitry is of a complex nature, so that subdivision into modules is required. Servicing time has to be minimised, so, taking advantage of the greatly reduced component failure rate, throw-away item value can be increased. Potting of modules is undertaken on this basis, further increasing inherent reliability. The

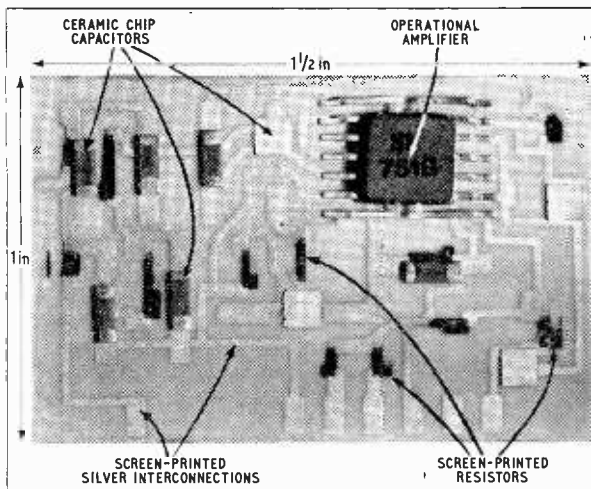
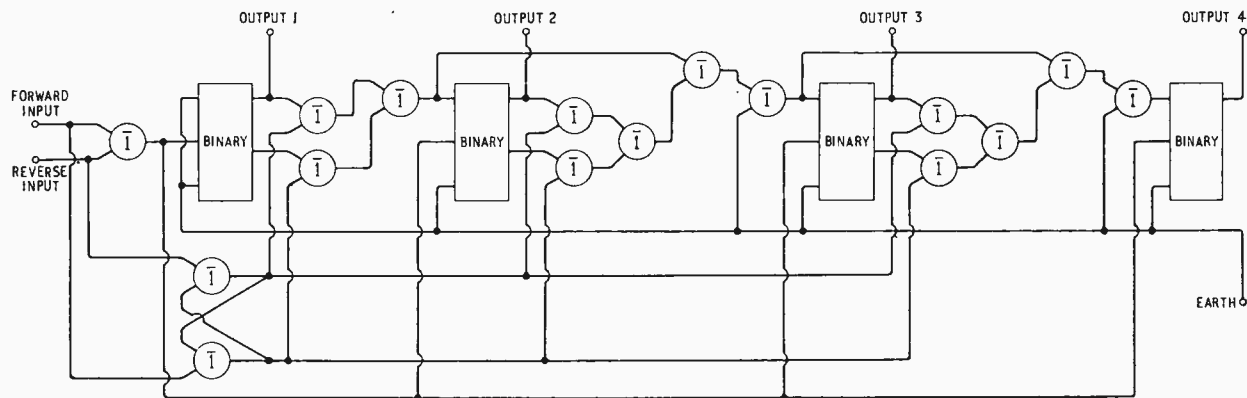

Fig. 1. Film circuit with printed passive components and a standard integrated-circuit amplifier.

*Plessey Company Ltd.



| OUTPUTS | 1 | 2 | 3 | 4 |
|---------|---|---|---|---|
| 1 | 0 | 0 | 0 | 0 |
| 2 | 1 | 0 | 0 | 0 |
| 3 | 0 | 1 | 0 | 0 |
| 4 | 1 | 1 | 0 | 0 |
| 5 | 0 | 0 | 1 | 0 |
| 6 | 1 | 0 | 1 | 0 |
| 7 | 0 | 1 | 1 | 0 |
| 8 | 1 | 1 | 1 | 0 |
| 9 | 0 | 0 | 0 | 1 |
| 10 | 1 | 0 | 0 | 1 |
| 11 | 0 | 1 | 0 | 1 |
| 12 | 1 | 1 | 0 | 1 |
| 13 | 0 | 0 | 1 | 1 |
| 14 | 1 | 0 | 1 | 1 |
| 15 | 0 | 1 | 1 | 1 |
| 16 | 1 | 1 | 1 | 1 |

Fig. 2. Schematic of reversible counter (above), with table (left) showing successive binary patterns from outputs 1, 2, 3 and 4.

method of interconnection varies according to the particular requirement. Where devices are to be attached to ceramic, re-flow soldering is deemed best. For printed-phenolic resin board, welding is used. The metallisation in this case is a cupro-nickel, permitting soldering as well, if required. Where the sub-modules mate to their mother board, wire wrapping can be used and film-wire forms make the inter-module connections. Heat dissipation will be by conduction to the outer case, thence by convection and radiation.

Circuit functions using s.i.c.s

The communications equipment designer is primarily concerned with analogue circuit problems. Integrated circuits now permit many of the solutions to these problems to take novel forms, and they also comply with the more stringent specification requirements. Digital methods can now be employed to carry out signal processing, taking advantage of two-state circuits that operate at very low powers and are capable of being compressed into a few chips of silicon. There are requirements for digital-to-analogue and analogue-to-digital conversion, but in most instances these can be supplied by monolithic s.i.c. operational amplifiers.

Control circuits.—The digital-to-analogue conversion requirement can be met using binary counters and summing amplifiers. This method is applied in the digital frequency synthesis system, where a frequency error is represented by a train of pulses derived from a series of digital dividers and a reference signal frequency. Fixing the tuning characteristics of any tunable circuits thus requires no moving parts and but a single crystal. Although this principle has been appreciated for many

years, only since the advent of s.i.c.s has it become a practical proposition³.

Fig. 2 shows a four-stage reversible counter capable of operating in sixteen states. A five-stage counter would have thirty-two states and so on. The information appearing on one or other of the input lines as a number of pulses represents the sense and amplitude of the error. The binary outputs, fed to a summing amplifier, produce a staircase voltage, capable of moving in 16 steps (for the 4-stage device) in either direction between zero and maximum voltage. If a voltage capable of varying over a range slightly greater than each step is also applied to the summing amplifier, a smooth output is obtained. This output voltage will be fed to the appropriate circuit to remove the error, at which stage the input pulse rate is zero. Thus, a closed-loop servo system is achieved, the pulse input being the coarse, and the ancillary voltage the fine control. Fig. 3 shows a summing circuit using an s.i.c. operational amplifier. The resistors are evaporated nichrome (thin-film) in order to attain the high degree of accuracy necessary for equal voltage steps.

Analogue-to-digital conversion methods can be simplified using s.i.c. operational amplifiers and gates. Fig. 4 shows a closed-loop servo system requiring four or so s.i.c. devices, a number of film resistors and a few discrete capacitors. The whole of this control circuitry can be accommodated in about one cubic inch and the power consumption would be about 1 W. Owing to the high open-loop gain of the amplifiers (about 70-80 dB), a high degree of stability will be maintained.

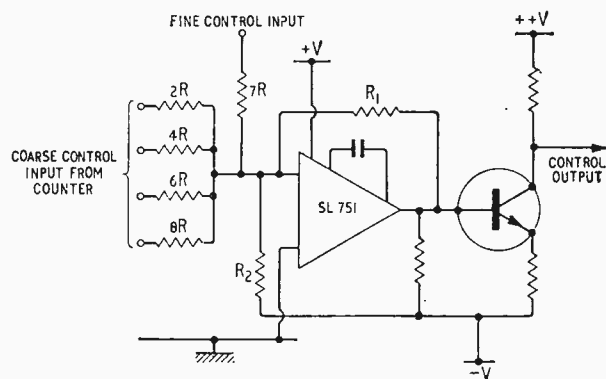

Fig. 3. Summing amplifier for use with Fig. 2 counter. Resistors NR and R₁ and R₂ are evaporated film components.

If the input error to the circuit is zero, the output from the squaring amplifier will be a train of pulses of fixed repetition rate and equal mark-space ratio. When an error signal is applied, this ratio will change in proportion to the magnitude and direction of the error. A differentiating circuit triggers a binary divider at the same repetition rate as the generator. The complementary outputs from this divider are fed to the two gates, together with the generator output, producing the outputs as shown. The transformed and rectified secondary output is used to eliminate the original error.

By the use of s.i.c. logic elements, interlocked and sequential switching circuitry can be simplified, considerably reduced in volume, and can operate at low power and need no moving parts. It is necessary only to produce the requisite logic levels ("0" or "1") at the appropriate inputs and use the resulting logic level at the terminal points to operate a p-n-p series transistor or n-p-n parallel transistor (for h.t. and earth switching respectively). (See *W.W.* August 1966.) Diodes of the p-i-n type so operated can be used for switching of r.f. signals, a typical application being common aerial operation in a transmitter/receiver.

Receiver circuits.—Integrated-circuit operational amplifiers ease the design of active filters. Applications for such filters in communications equipments are in a.g.c. amplifiers, a.f. input and output stages and servo loops. As the operational amplifier has a large open-loop gain, high degrees of stability can be achieved by setting the pass-band closed-loop gain fairly low. $1/A$ will be small, so the gain will be $= 1/B$. Having set the pass-band gain, the transfer function required to give the specified cut-off frequency, pass-band ripple and degree of attenuation in the stop-band is obtained by solving standard equations and inserting values in the chosen configuration. Fig. 5 shows a second-order low-pass Sallen and Key filter. The pass-band gain and the attenuation characteristic are set by the R and C networks.

In order to achieve high Qs, good Q stability, and the filter characteristics of either high, low or band pass, three series-connected amplifiers can be used¹. Such a three-stage device with an open-loop gain high enough to achieve Qs of 200 with a high degree of stability is currently being designed on a single silicon chip. Apart

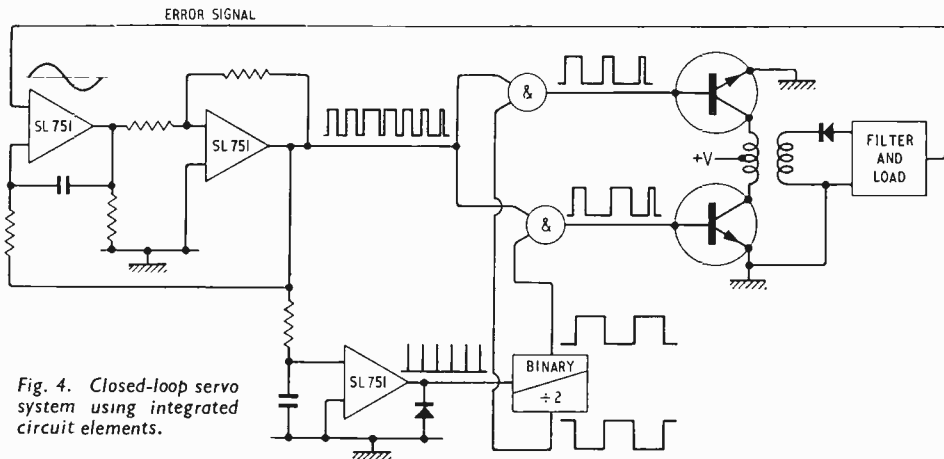

Fig. 4. Closed-loop servo system using integrated circuit elements.

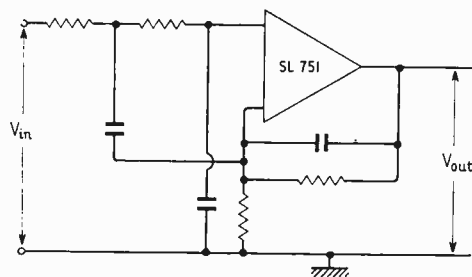

Fig. 5. Second-order low-pass filter using a standard integrated circuit operational amplifier.

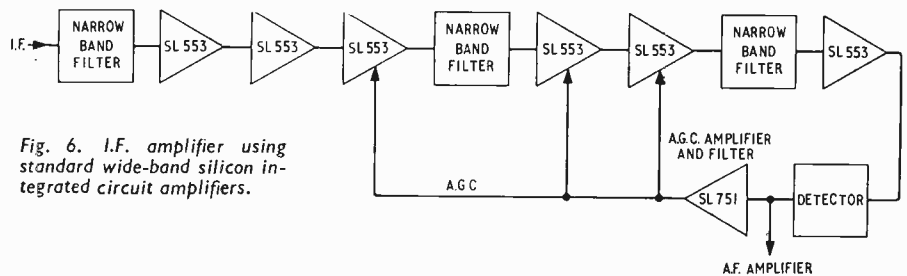

Fig. 6. I.F. amplifier using standard wide-band silicon integrated circuit amplifiers.

from the easing of design and the improvement in attainable characteristics, such filters would comprise no more than a single s.i.c., some film resistors and, eventually, film capacitors. The whole could thus be made very small—no more than about half a cubic inch.

The appearance of wide-band amplifiers capable of operating up to 120 Mc/s or more has eased considerably the problem of i.f. amplifier design². Such an amplifier, shown in Fig. 6, using six of these devices, has a gain of 110 dB at 50 Mc/s and an a.g.c. capability of about 90 dB. The only other components needed are one load resistor and one 1000 pF coupling capacitor per device. The bandwidth restriction is achieved by the insertion of crystal filters, but tuned stages using printed inductors can be employed equally well.

The detector stage can be designed as a monolithic device. A breadboard circuit as shown in Fig. 7, built from three silicon integrated transistors on a single chip and discrete resistors, gives about 1 or 2% distortion from a 100% modulated 50 Mc/s input, with a swing of about 2V peak-to-peak. The diode is a base-to-collector shorted transistor of the same type as the other two.

The a.g.c. amplifier would be an active filter using an operational amplifier.

Audio frequency amplifiers have been made on single

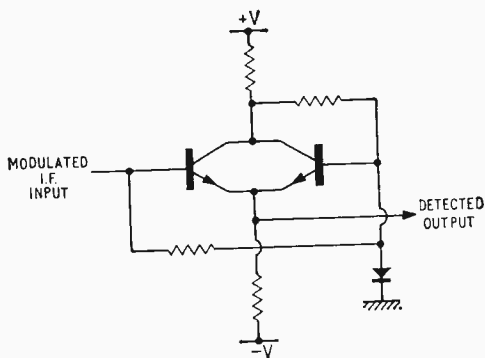

Fig. 7. Possible arrangement for an integrated-circuit detector.

silicon chips, but one of the difficulties has been that of trying to produce good p-n-p integrated transistors of an economical size on the same chip as n-p-ns. There are several methods of producing s.i.c. audio power stages. Complementary pair packs are produced by mounting n-p-n and p-n-p transistors individually and internally connecting them. A system using only n-p-ns can be used to feed a single-ended 50 Ω load and such a device has been bread-boarded. It was capable of giving 300 mW of a.f. power, but suffered from high primary power consumption. The distortion (about 4%) was also higher than could be tolerated. An amplifier is now being developed which will deliver the required 300 mW and is about 50% efficient. It requires, however, a large capacitor on the output.

Integrated circuit methods permit the i.f. amplifier, detector, a.g.c. amplifier and a.f. power stage to be designed into a volume of about 2 $\frac{1}{2}$ -3 cubic inches.

Trends and possible developments

Communications equipments now under development use readily available s.i.c. devices. There are, however, many places where special-purpose design of s.i.c. monolithic circuits is attractive in terms of decreased mechanical complexity and reduction of the number of external interconnections and discrete or film components. Indications are that by so reducing external interconnections, an improvement in the reliability of the circuit concerned would be achieved. Logic functions are particularly adaptable to this approach. The reversible counter, at present requiring seven or eight separate flat packs, can be made as a single monolithic chip, since only eight connections are required for its function. Logic in the interlock circuitry could be purpose-designed into considerably fewer than the number of devices presently required. Some of the linear functions (the detector and a.f. amplifier for example) can also be designed readily into monolithic form. Already, each decade divider used in a frequency synthesizer, at present comprising about 12 separate s.i.c. devices, is being designed into a single chip, with the ultimate possibility of putting all of the five divider stages into a similar form. This indicates what should be the correct approach to logic system design. The logic function requirement, having been determined, should be bread-boarded using "off-the-shelf" devices, such as multiple gates, binaries, and so on, then further designed into the minimum number of distinct packages, the limitations being only the number of input and output loads required.

The optimum size of chip is subject to debate, but something like a 100 thou. square can contain a vast amount of circuitry, particularly with the ever-increasing resolution attainable in the photoetching process allowing smaller and smaller integrated components. A chip of this size could contain about 40-50 transistors and 100k Ω of resistance.

It should be noted that with s.i.c.s no further work is required after the circuit has been designed and developed for it to go into large scale production. Once the masks have been made, they are good (within practical limits) for all time. Although the initial costs of design and development of circuits into monolithic form may possibly be higher than designing in discrete component form, they will be absorbed rapidly, even in small quantity production. A requirement for only a thousand or so devices of any one circuit is generally sufficient justification for its design into monolithic form. Each different circuit is purely a variation in two-dimensional geometry—the manufacturing processes are fixed.

New factors in circuit design

The examples considered above show how familiar communications equipment circuit functions can be modified to take advantage of the new techniques available. What was totally impracticable in discrete component form now becomes the optimum solution to many of the problems. There are limitations, of course, but on examination these are found, in many cases, to be advantageous. Low power handling capabilities lead the designer to carry out as much circuit action at low voltage and current levels as possible, only up-rating the power when finally necessary. There are upper frequency limits due to parasitic capacitances inherent in the diffusion processes. The absolute accuracy of values is of the order of only 15-25%, but relative values are much more closely matched. Matching of transistor characteristics on any individual chip is close, eliminating the tedious and often expensive process of attempting to match individual transistors. In many circuit applications, ratios are much more important than absolute values and this feature is now readily available. The same applies to screen printed components, although these can be adjusted after manufacture, which s.i.c.s cannot. Evaporated film components (resistors mainly at present) are highly stable and can be very accurately adjusted. They also enjoy very low temperature co-efficients.

Some of the material in this article has resulted from work carried out by engineers under Mr. K. F. Warwick of the Ilford Development Unit, Plessey Company Ltd., Electronics Group. The author wishes to thank them for invaluable assistance given in the preparation of these relevant parts of the article and the directors of the Plessey Company Ltd. for permission to publish it.

REFERENCES

1. "SL 700 Series Operational Amplifiers. Issue 2" Semiconductors Ltd. Publication No. S.1201 B.
2. "SL 503, A Wideband Amplifier." Semiconductors Ltd. Publication No. S.1210 A.
3. "A 28000 Channel Frequency Synthesizer in 10 Cubic Inches," by D. J. Martin. Southampton University Microelectronics Symposium 1965. I.E.E. Conference Publication No. 14.
4. "SL 500 series Wideband Amplifiers," Semiconductors Ltd. Publication No. SA1/1209.

CONFERENCES AND EXHIBITIONS

Latest information on events in the U.K. during 1967, is given below.
Further details are obtainable from the addresses in parentheses.

LONDON

- Jan. 23-26 Savoy Place
Acoustic Noise and Its Control
(I.E.E., Savoy Pl., W.C.2)
- Feb. 15-16 Savoy Place
Technique and Application of Electron Probe Microanalysis
(Inst. P. & Phys. Soc., 47 Belgrave Sq. S.W.1)
- Mar. 13-17 Savoy Place
Air Traffic Control Systems Engineering
(I.E.E., Savoy Pl., W.C.2)
- Mar. 13-17 Earls Court
Medical Engineering & Automation Exhibition (Medea)
(Electronic Engineering Assoc., 11 Green St., W.1)
- Mar. 14-16 King's Head, Harrow
Public Address Exhibition
(A.P.A.E., 394 Northolt Rd., South Harrow, Middx.)
- Mar. 30-Apr. 2 Hotel Russell
Audio Festival and Fair.
(C. Rex-Hassan, 42 Manchester St., W.1)
- Apr. 11 & 12 Savoy Place
Plastics in Telecommunication Cables
(Plastics Institute, 6 Mandeville Pl., W.1)
- Apr. 17-19 University College
Elementary Particles
(Inst. P. & Phys. Soc., 47 Belgrave Sq., S.W.1)
- Apr. 17-20 Alexandra Palace
Physics Exhibition
(Inst. P. & Phys. Soc., 47 Belgrave Sq., S.W.1)
- May 8-10 Savoy Place
Static Electrification
(Inst. P. & Phys. Soc., 47 Belgrave Sq., S.W.1)
- May 22-24 Savoy Place
Frequency Generation and Control for Radio Systems
(I.E.E., Savoy Pl., W.C.2)
- May 23-26 Olympia
Radio and Electronic Component Show
(R.E.C.M.F., 6 Hanover St., W.1)
- July 3-5 Imperial College
Electron Diffraction
(Inst. P. & Phys. Soc., 47 Belgrave Sq., S.W.1)
- July 17-22 Imperial College
I.Q.S.Y./COSPAR Joint Scientific Symposium
(I.Q.S.Y. Secretariat, 6 Cornwall Terr., N.W.1)
- July 24-28 Imperial College
COSPAR International Space Science Symposium
(I.Q.S.Y. Secretariat, 6 Cornwall Terr., N.W.1)
- Sept. 11-15 Olympia
Industrial Photographic & Television Exhibition
(Industrial & Trade Fairs, Commonwealth House, New Oxford St., W.C.1)
- Sept. 11-15 Olympia
Engineering Materials and Design Exhibition and Conference
(Industrial & Trade Fairs, Commonwealth House, New Oxford St., W.C.1)
- Sept. 13 & 14 Savoy Place
High-voltage Insulation in Vacuum
(Inst. P. & Phys. Soc., 47 Belgrave Sq., S.W.1)
- Sept. 26-28 Savoy Place
Magnetic Materials and their Applications
(I.E.E., Savoy Pl., W.C.2)

Sept. 27-30 Horticultural Hall
R.S.G.B. Radio Communications Exhibition
(P. A. Thorogood, 6 Museum House, Museum St., W.C.1)

Nov. 8-10 Savoy Place
M.F., L.F., and V.L.F. Radio Propagation
(I.E.E., Savoy Pl., W.C.2)

Dec. 5-7 Savoy Place
Electrical Methods of Machining and Forming
(I.E.E., Savoy Pl., W.C.2)

BRISTOL

Apr. 11-14 The University
Advances in Computer Control
(I.E.E., Savoy Pl., London, W.C.2)

CANTERBURY

Mar. 30-31 The University of Kent
Transport Properties of Superconductors
(Inst. P. & Phys. Soc., 47 Belgrave Sq., London, S.W.1)

EASTBOURNE

Apr. 11-12 Grand Hotel
New Developments in Optics and their Applications in Industry
(British Scientific Instrument Research Assoc., South Hill, Chislehurst, Kent)

EXETER

Apr. 12-14 The University
The Teaching of Mathematics to Physicists
(Inst. P. & Phys. Soc., 47 Belgrave Sq., London, S.W.1)

GREAT MALVERN

Apr. 24-26 Royal Radar Establishment
Image Detection and Processing
(Inst. P. & Phys. Soc., 47 Belgrave Sq., London, S.W.1)

HARROGATE

June 7-9
Industrial Physics—The Contribution of Government-Sponsored Laboratories
(Inst. P. & Phys. Soc., 47 Belgrave Sq., London, S.W.1)

LIVERPOOL

Apr. 5-7 The University
Spark Discharges
(Inst. P. & Phys. Soc., 47 Belgrave Sq., London, S.W.1)

MANCHESTER

Jan. 4-7 The University
Solid State Physics
(Inst. P. & Phys. Soc., 47 Belgrave Sq., London S.W.1)

July 18-20 The University
Computer Technology
(I.E.E., Savoy Pl., London, W.C.2)

Sept. 26-30 Belle Vue
Electronics, Instruments, Controls & Components Exhibition
(Institution of Electronics, Pennine House, Shaw Rd., Rochdale, Lancs.)

NOTTINGHAM

Jan. 3 & 4 The University
Progress In Automated Assembling
(I.Prod. E., 10 Chesterfield St., London, W.1)

Apr. 3-5 The University
Resistive and Dielectric Properties of Thin Films
(Inst. P. & Phys. Soc., 47 Belgrave Sq., London, S.W.1)

READING

Apr. 12 & 13 The University
Point Defects in Metals
(Inst. P. & Phys. Soc., 47 Belgrave Sq., London, S.W.1)

Logical Door-lock

By B. CRANK

OPENED BY SETTING TWO CONSECUTIVE COMBINATIONS ON DECADE SWITCHES:
EXTRA SECURITY GIVEN BY TIME LIMITATION FACILITY

THE combination lock to be described was designed for a number of differing applications. Several versions have been developed, from a very simple basic lock to ones with internal and external alarms. In general the more complex the lock the more protection it affords the user and the more expensive it is to build.

All the locks are, in the main, battery operated and, with one exception only, consume power when being opened or closed. Tampering with any of the leads coming from the unit will not help anyone trying to open the protected building or safe unlawfully; in fact, in most cases it will be very much to his disadvantage. In the event of the internal batteries becoming exhausted, external batteries can be connected by means of an external plug and socket.

To open any of the locks it is necessary to set two consecutive three-figure combinations on three ten-way switches, and in most cases there is a maximum time

B. S. CRANK, who served as a navigational instrument fitter in the R.A.F. for 12 years until last September, is now on the editorial staff of *Wireless World*. For the last five years of his service he was at R.A.F. Finningley, Yorks, fault finding on electronic equipment in Vulcans. Two of his ideas for modifications to aircraft auto-flight systems have been accepted by the R.A.F.

within which these operations must be completed. Failure to set the two combinations within the specified time limit will result in cancellation of the correctly set first combination, and the sounding of an alarm (if fitted). The combination switches have no stops and can be rotated in either direction continuously. It is necessary to move the switches in the correct direction in order to set the second combination; moving the switches in

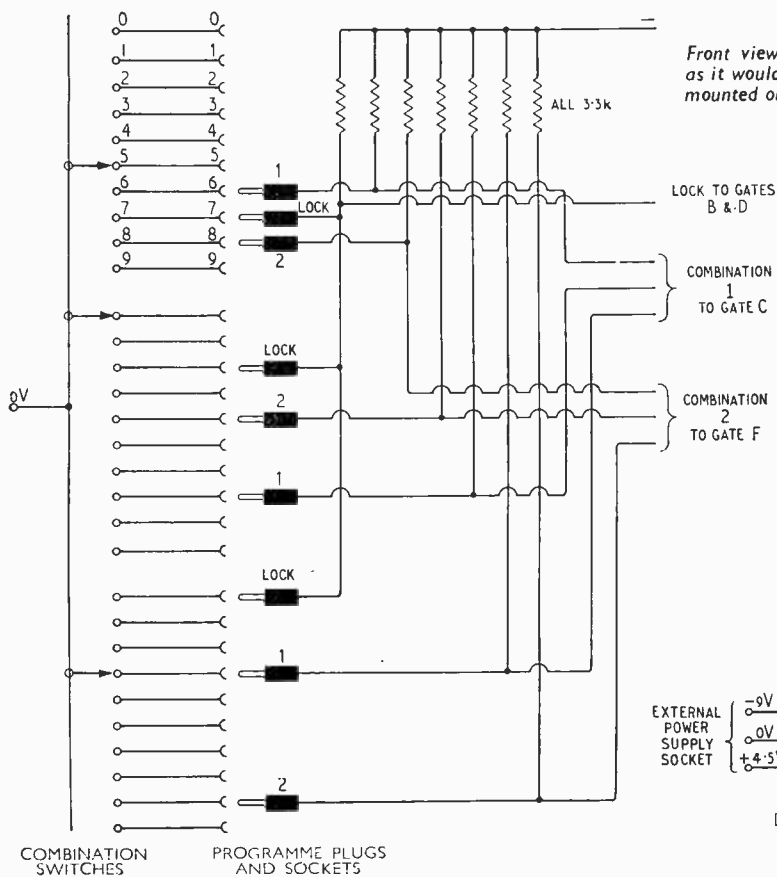
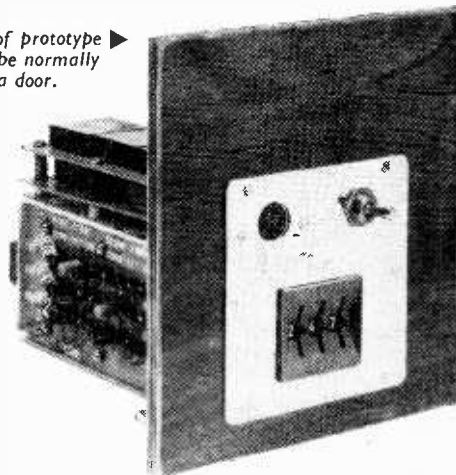
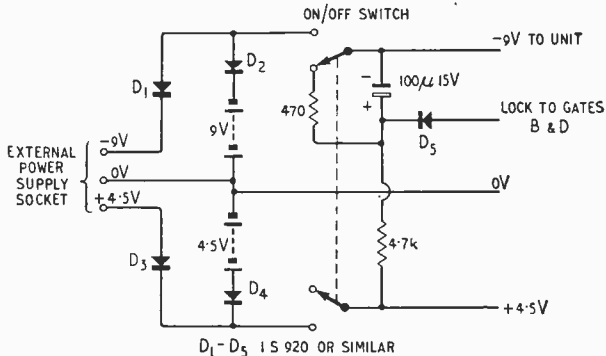

Fig. 1. Combination switches and programming unit.

Front view of prototype as it would be normally mounted on a door.



Below: Fig. 2. Power supply circuit.



the incorrect direction will have the same effect as exceeding the time limit.

All the locks described are constructed from Series 40 digital modules manufactured by S.T.C. These modules employ resistor-transistor logic and use conventional components; they are potted in epoxy resin and housed in polystyrene cases. The connection pins are arranged so that they conform to a 0.1 inch matrix, making them suitable for mounting on Veroboard. The functions of the modules used are as follows:—

4 OR 1 Gate. White case.—This module is a four-input OR gate. Any of its inputs going negative (-5V to -8V) results in the output also going negative.

4 NOR 3 Gate. Green case.—This four-input NOR gate performs the following function. Any of its inputs going negative will result in the output going to zero volts. The "3" in the type number signifies that it is capable of driving three other modules. If any input is short circuited to 0 volts or open circuit the output will be negative.

Buffer Amplifier. Blue case.—This unit is used as a relay driver in the lock. When the input goes negative a relay connected to the output is energized. The relay must not consume more than 50 mA.

Bistable. Red case.—This module is used as a d.c. set/reset bistable. In this mode it has two inputs and two outputs. The outputs are labelled 0 and 1. When the "set" input goes negative the "1" output also goes negative and the "0" output goes to zero volts. The bistable will remain in this condition until the "reset" input goes negative, then the states of the outputs will change over and remain in this condition until the bistable is once again set.

Flip Flop. Yellow case.—When this module receives an input pulse or a logical change from the zero-volts state to the negative-volts state it is triggered into its quasi-stable condition for a period of time determined by an external capacitor. At the end of this time, in changing back to its stable state a $200\mu\text{sec}$ pulse is generated by the module.

Combination switch circuits.—The circuitry associated with the combination switches is shown in Fig. 1. The switches used in the prototype were edgewise thumb-wheel switches which could be rotated continuously in either direction. However, conventional switches could be used provided they were not fitted with stops; this would mean a much larger front panel but the lock would be less expensive to build. It can be seen that all positions of the switches are connected to wander sockets, three wander plugs being provided for each switch. Two of these plugs are used to programme the combinations, the third being used to set the direction that the switch must be rotated between the two combinations. There are three outputs from the circuit, combination one, combination two and lock. All these outputs are normally negative-going by virtue of the resistors connected to the negative line. The switch wipers are all connected to 0V. Should the bottom end of one of the resistors, and therefore an output line, be connected by one of the switches to 0V then that output line will be zero volts. The first combination set in Fig. 1 is 673 and the second 848. If in moving the switches from the first combination to the second a "lock" position is passed, the effect of setting the first combination will be cancelled. It is therefore the position of the lock

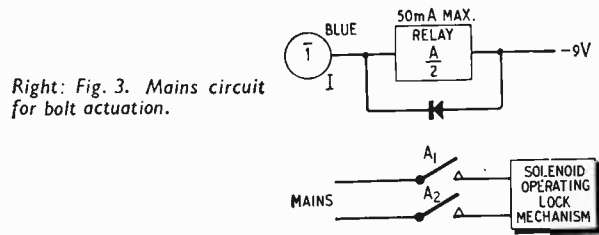

Right: Fig. 3. Mains circuit for bolt actuation.

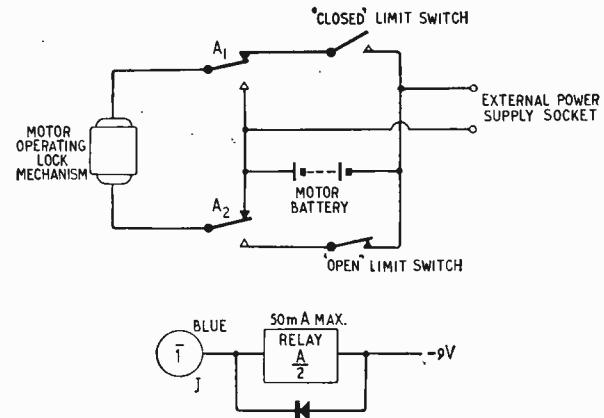

Fig. 4. Battery circuit for bolt actuation.

plugs that determines the direction that the switches have to be moved.

Fig. 2 shows the power supply arrangements, which are formed by two batteries, 9V and 4.5V. The diodes D_1 to D_4 isolate the internal batteries from the external power supply socket and vice versa; this ensures that no advantage can be obtained by short circuiting the power supply socket. On switch-on the lock output goes negative for a short period, then as the $100\mu\text{F}$ capacitor charges the cathode of D_5 falls through 0V and becomes reverse biased. The lock output can now be considered open circuit. The 470Ω resistor discharges the capacitor rapidly at switch-off; this ensures that operating the switch quickly on and off does not affect the operation of the unit.

Bolt actuation and alarm circuits.—There are two bolt actuating circuits, as shown in Figs. 3 and 4. If, in the mains version in Fig. 3 the input to the buffer amplifier, circuit reference I, goes negative, relay A/2 will be energized and the contacts will close, so applying mains voltage to the solenoid which will withdraw the bolt. The diode across the relay prevents the build-up of high voltages that would otherwise damage the buffer amplifier. If the specified solenoid is used it must not be energized for more than ten minutes, time being allowed for it to cool after this. The solenoid is rated at $1\frac{1}{2}\text{lb}$ over a stroke of $\frac{1}{2}\text{inch}$.

If an all-battery version of the lock is required the circuit of Fig. 4 is included. Here the bolt is withdrawn by a small suitably geared motor. When relay A/2 is energized the polarity of the supply to the motor is such that it causes the motor to run in the correct direction required to withdraw the bolt until the "open" limit switch is broken. When A/2 is de-energized the supply to the motor is reversed and the bolt is driven home until the "closed" limit switch is broken. Provision

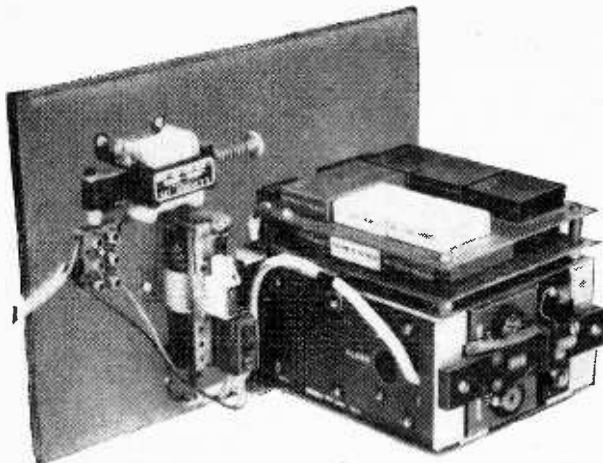

Rear view showing layout of principal parts.

should also be made to connect external batteries if necessary via the external power supply socket.

The other output of the system is the external alarm, and this shown in Fig. 5. A negative signal to a buffer amplifier energizes relay B/2, which then holds on via contact B1. Contact B2 closes and sounds the alarm bell. If an internal alarm system is used a push-to-break switch inside the protected unit de-energizes relay

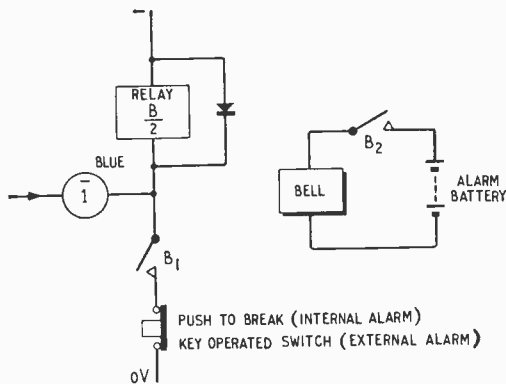
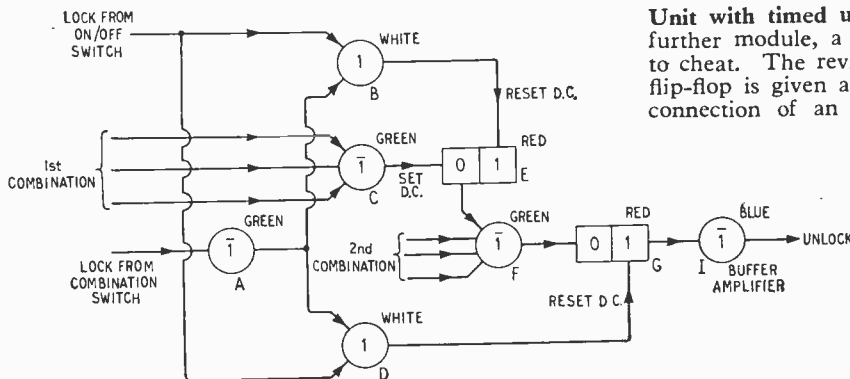
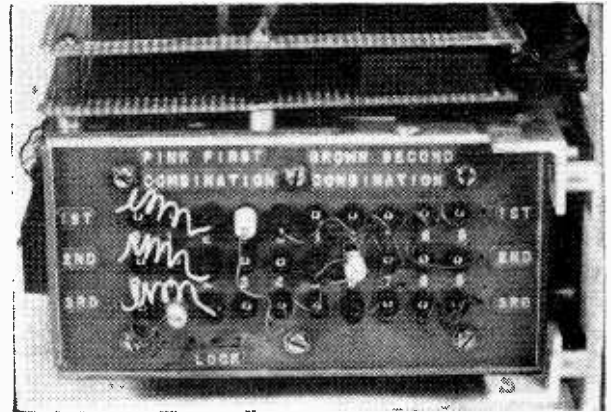

Fig. 5. Alarm circuit.

Fig. 6. Logic arrangement for the basic lock.



Programme patch board. The method of setting combinations can be clearly seen.



B/2. In the external alarm a key-operated switch is used that could be arranged to disconnect the alarm unit's batteries.

Logic for basic lock.—The logical diagram of the basic lock is shown in Fig. 6. On switching on the lock from the on/off switch line goes negative for a short period; this voltage is applied to the reset d.c. inputs of bistables E and G via the OR gates B and D and ensures that both bistables start in the "0" condition. All input lines from the combination switches are negative, resulting in the outputs of the NOR gates A, C and F being at zero volts. On selecting the first combination (673 in Fig. 1) all input lines to NOR gate C go to zero volts and the output of C sets bistable E. Because the bistable has now changed into its "1" state, one of the inputs to NOR gate F has gone to zero volts. The second combination (848 in Fig. 1) is now set. Provided that the switches are moved in the correct direction, all input lines to NOR gate F will be at zero volts and bistable G will be set. The input to the buffer amplifier I withdraws the bolt as previously described. If the combination switches had been moved in the incorrect direction the lock line to NOR gate A would have gone to zero volts, the resulting negative signal being applied to the reset inputs of both bistables via OR gates B and D. When the second combination was reached the lock would not open because the output of gate F could not go negative because of the negative signal it is already receiving from bistable E. It would now be necessary to set both combinations again to open the lock.

Unit with timed unlock facility.—The addition of one further module, a flip-flop, makes the lock far harder to cheat. The revised circuit is shown in Fig. 7. The flip-flop is given a time constant of 10 seconds by the connection of an external 1,000 μ F capacitor. When bistable E is set by the selection of the first combination, the flip-flop H is also triggered. After the 10-second timing period the 200 μ s pulse output of the flip-flop resets bistable E via OR gate B. This means that the second combination has to be set within 10 seconds of the first to open the lock. This timing period can, if desired, be increased up to 30 seconds by con-

necting larger external capacitors to the flip-flop. It is now virtually impossible to open the lock by sequentially trying all possible combinations.

Unit with internal alarm.—The flip-flop fitted in the last-mentioned unit provides a means of determining whether the lock is being tampered with. The most obvious way for the unenlightened to attempt to open the lock is to select each combination in turn until all possible combinations have been set. Sooner or later the first combination must be hit upon, although there is no outward indication that this has happened. It can be concluded that if the output pulse from the flip-flop arrives before bistable G has been set and the lock opened, the lock is being tampered with.

The extra modules to detect and act on this are shown in Fig. 8. The alarm bistable, L, is reset at switch-on by the lock from the on/off switch line. The output from the flip-flop is normally at zero volts; therefore, the output from NOR gate J is negative and that of K at zero. When the lock is being operated normally, bistable G is set and the output of NOR gate K is held to zero. Should G not be set the negative pulse from the flip-flop results in the output of NOR gate J going to zero and K going negative to set bistable L. Relay B/2 is energized via buffer amplifier M and the internal alarm bell rings. As relay B/2 has its own hold circuit, switching off the control unit does not switch off the bell. This is cancelled by a push-button behind the locked door. When the alarm is sounded, as before bistable E is reset so it is still necessary to reselect both combinations. It will be noticed that the function of bistable L could just as well be carried out using a flip-flop, its only real purpose being to give the relay time to operate. The difference in price between the two modules is very small, and as the bistable requires some 5 mA less battery current and does not require an additional capacitor the bistable was used. If the combination switches are moved in the incorrect direction between combinations the positive-going level change due to bistable E being reset changes the state of the flip-flop prematurely and sounds the alarm.

If required, a trembler switch could be connected from the nega-

tive supply line and via an OR gate to the "set" input of bistable L; then, should the unit be subjected to any rough treatment, the alarm will be sounded.

Unit with external alarm.—If the cables to an alarm unit could be satisfactorily concealed there is no reason why such an alarm unit could not be mounted externally. Any tampering with the cables to the unit would render the alarm inoperative. To correct this shortcoming the alterations shown in Fig. 9 are made. The price that has to be paid for this added protection is a modified power supply arrangement that results in a small continuous drain on the logic system's battery, separate batteries for the alarm unit that draw current continuously and an additional NOR element. The output to the alarm unit is taken from the "0" output of bistable L instead of the 1 output as before. It is necessary to invert this at the alarm unit, and this is done by the additional NOR module. Should the alarm line ever go to zero the alarm will be sounded. This can be achieved by setting bistable L, cutting the alarm line or by short circuiting it to the common 0 V line that must also go to the external alarm unit.

It follows that when the control unit is switched off the alarm line must not be allowed to go to zero. To prevent this the power supply circuits are modified as shown in Fig. 10. A 3.3 kΩ resistor is connected to battery negative before the on/off switch. The bottom end of this resistor is connected to an OR gate formed by the diodes D₆ and D₇, so that with the main switch off

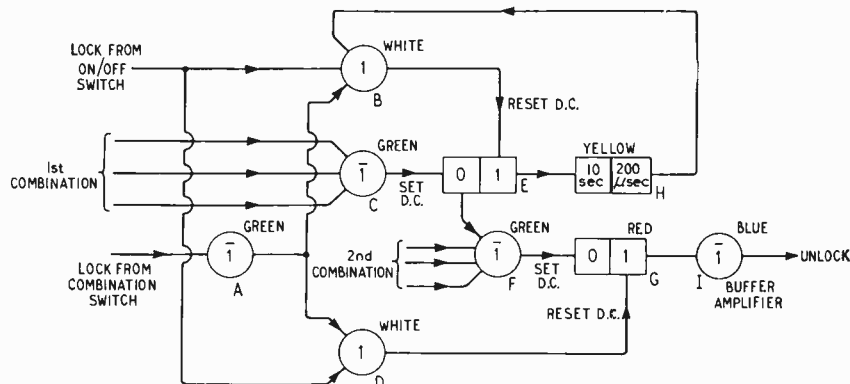

Fig. 7. Logic arrangement for lock with time-limit facility.

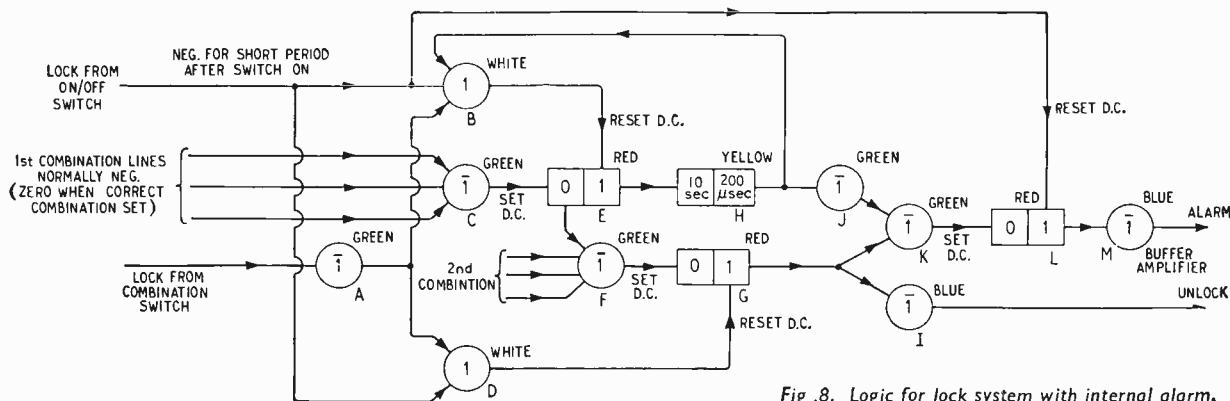

Fig. 8. Logic for lock system with internal alarm.

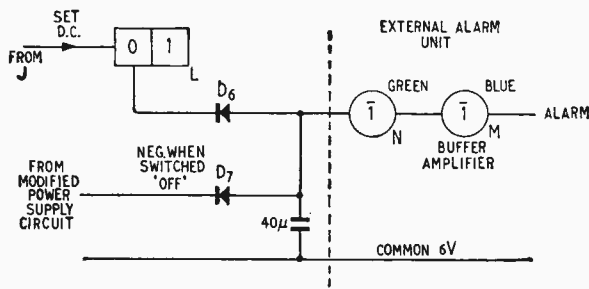

Fig. 9. Arrangement for an external alarm.

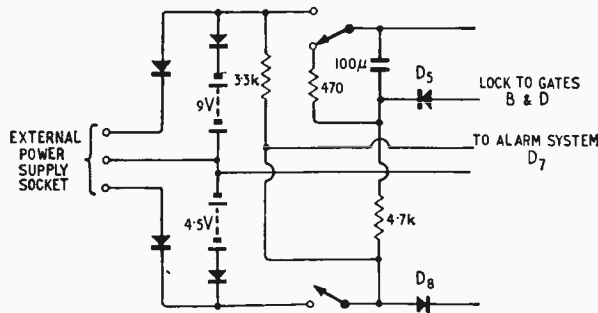

Fig. 10. Modified power unit for use with locks fitted with external alarm.

the alarm line is held negative. With the main switch on, the bottom end of the 3.3 k Ω resistor is connected directly to the positive line so that D₇ becomes reverse biased. The 40 μ F capacitor across the alarm line holds the line at negative volts during switch over. D₈ prevents the positive line from going negative when the main switch is off. The main disadvantage of the external alarm system is the continuous drain on the batteries, as shown in the table below. This could be overcome by making the alarm unit mains powered, but has been avoided as all that would be necessary would be to turn the mains off to render the alarm system inoperative. Probably the best solution would be to use rechargeable batteries on continuous trickle charge. The method used is best decided when individual circumstances are known, and for this reason the choice is left to the constructor.

Battery consumption of unit with external alarm.—The following figures were taken from the writer's unit, which employed a 1k Ω relay in the logic unit and a 500- Ω relay in the alarm.

| Condition | Control Unit | | External Alarm Unit | |
|-----------|--------------|-------|---------------------|-------------|
| | 9 V | 4.5 V | 9 V | 4.5 V |
| Off | 600 μ A | 0 | 6.1mA | 600 μ A |
| On | 64mA | 5.3mA | 6.1mA | 600 μ A |
| Unlock | 71mA | 5.4mA | 6.1mA | 600 μ A |
| Alarm | 64mA | 5.3mA | 26mA | 600 μ A |

Construction.—No detailed constructional information is given because of the number of variations to the unit that are possible. In the prototype all modules were mounted on Veroboard. It will be found that each module uses the same pins for power supplies and that the pins are staggered; this means that if the modules are mounted in line all the power supply pins are in alignment, greatly reducing the amount of wiring necessary. Pin layout of

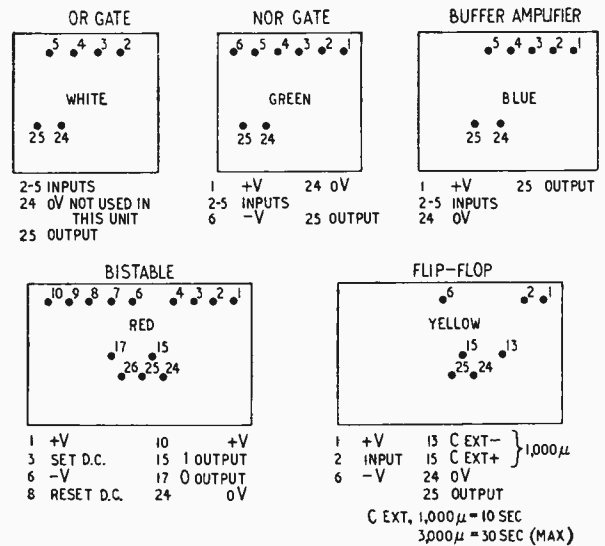

Fig. 11. Connections on the logic modules.

the modules is shown in Fig. 11, only the pins used in this unit being labelled. It is strongly advised that some colour coding of wires should be adopted to avoid confusion. It is also advisable to make sure that the lock is well tested before putting into service, as any malfunction will almost certainly result in the lock becoming impossible to open.

The modules have a nominal operating life of seven years and a sample failure rate of 0.001% per 1,000 module hours. Finally, if one wishes to fit a time switch to the lock so that it can only be opened at certain times, then the time switch could be wired so that when the lock is to be inhibited the inputs to gates B and D are negative.

MAJOR COMPONENTS LIST

Modules

- Type 40A, 4 NOR 3 Gate, green case.
- ” 40B, 4 OR 1 Gate, white case.
- ” 42A, Buffer Amplifier, blue case.
- ” 43A, Register/Bistable, red case.
- ” 43B, Delay/Monostable, yellow case.
- Electroniques (Standard Telephones & Cables Ltd.)
Edinburgh Way, Harlow, Essex.

Combination switches

- 3 ZN/010 multiswitch wafer (single pole, 10 way).
- 1 ZN/206 mounting bracket.
- 1 ZN207 mounting bracket.
- 2 assembly rods size 3.
- 4 assembly nuts.

Kynmore Engineering Co. Ltd., 19 Buckingham St., London, W.C.2.

Solenoid Type SAM/T/HOR/230/50/3.

R. A. Webber Ltd., Knapps Lane, Bristol 5.

30 miniature wander sockets.

9 wander plugs to suit.

100 μ F 15 V capacitor.

1000 μ F 15 V capacitor.

470 Ω resistor, $\frac{1}{4}$ watt.

4.7k Ω resistor, $\frac{1}{4}$ watt.

3.3k Ω resistors. Quantity depends on unit being built.

One or two relays. Two-pole make. (2P C/O motor lock.)

Minimum coil resistance 180 Ω .

All additional diodes 1S920 or similar.

Double-pole changeover switch.

Push-to-break switch or key-operated switch.

Transistor Metal Locator

By T. E. ESTAUGH

THE metal locator that forms the basis of this article is sufficiently sensitive to detect fairly large masses of metal buried to a depth of two feet or so, and will detect a coin the size of a half-crown when it is buried to a depth of about two inches. In the six months since its construction it has succeeded in locating buried shrapnel, beer cans, scrap iron, and one badly corroded penny of 1905 vintage. It has also proved invaluable in tracing water pipes and heavy cables concealed behind walls or buried underground.

Principle of operation

The basic principle of operation is simple and relies on the fact that the inductance of a coil is changed when it is placed near to any mass of metal; by making a coil form part of the tuned circuit of an LC oscillator, the operating frequency is changed when any metallic object is moved into the field of the coil, and this change in frequency may be used to give either an aural or visual indication of the presence of the metallic object. To detect the presence of metal at a reasonable range, the coil must have a fairly large field, and this means that the coil must have a diameter of several inches; such a coil may be built into a head that may be moved manually to search for the presence of any metallic object.

The block diagram of the system is shown in Fig. 1. The search coil is built into the search head and tuned by the pre-set capacitor C_1 , and by the variable capacitor C_2 ,

which is built into the main body of the unit, and this combination is used as the tank circuit of the variable frequency oscillator. To enable small changes in frequency to be detected, the outputs of this variable frequency oscillator and a second, fixed frequency, oscillator are both fed into a common detector or mixer circuit and the high frequency components of the resulting signal are then removed by a filter; the output of the filter is thus a beat frequency that is equal to the difference between the two oscillator frequencies. This beat note is fed to an audio amplifier and is finally heard at reasonable level in a crystal earpiece.

In use, C_1 and C_2 are adjusted to produce a near-zero

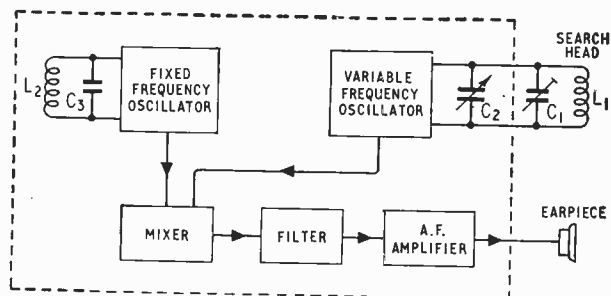

Fig. 1. Block diagram of metal location system.

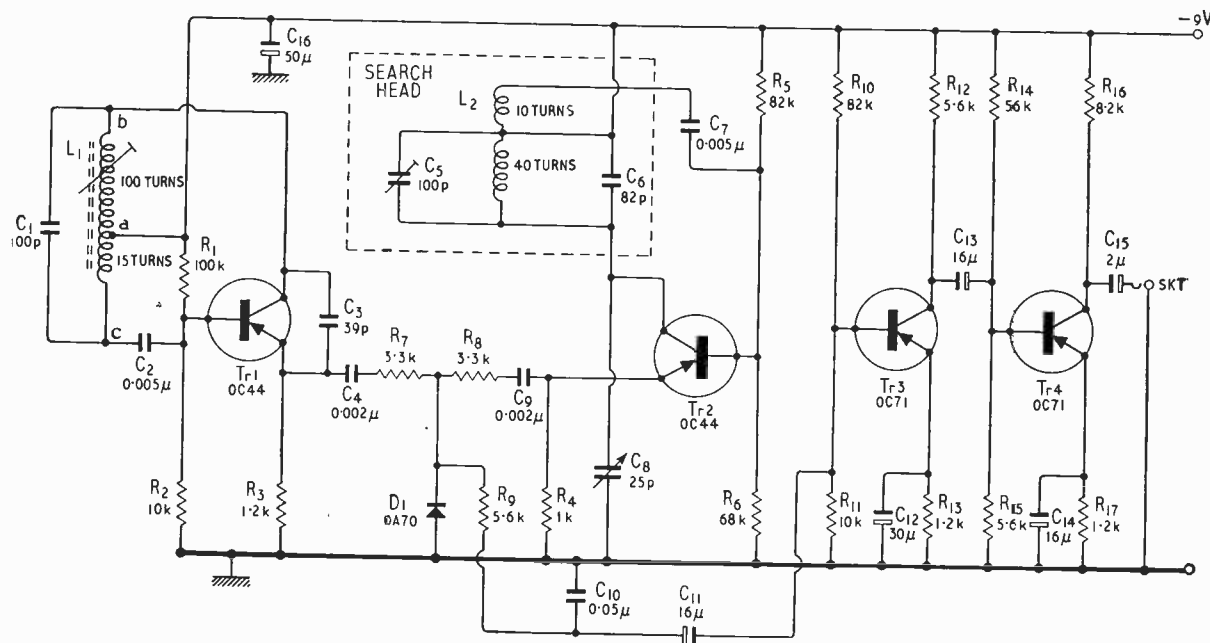

Fig. 2. Metal locator circuit. All resistors are 10% tolerance, 1/2 W.

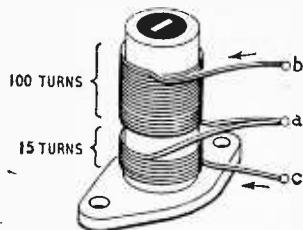

Fig. 3. Details of L_1 . Winding consists of 115 turns 38 s.w.g. enamelled wire scramble wound on a $\frac{1}{4}$ in dia. former, with core, and tapped at 15 turns.

beat note in the earpiece in the absence of metal; the search head is then moved over the ground manually, and if any metal is in the area a sharp rise or fall in the beat note will be heard as it enters or leaves the field of the search coil.

It has been pointed out that the search coil should have a diameter of several inches, but since the inductance of a coil with a given number of turns increases as its diameter is increased, its inductance will be quite large if a reasonable number of turns is used. To ensure that the operating frequency is not greatly affected by variations in stray capacitance, this coil should be tuned by a fairly large capacitance, and the resulting tuned circuit will thus have a fairly low operating frequency, too low, in fact, for direct beating of the two oscillator frequencies to be obtained.

This minor snag can be overcome by ensuring that the output of the low frequency oscillator is rich in harmonics, and one or other of these harmonics may then be used to produce the beat note that is required. This system has a number of inherent advantages. If, for example, the circuit operates at a basic frequency of 20 kc/s, and its tenth harmonic is used to produce the beat note, a change in real frequency of only 10 c/s will result in a change of 100 c/s in the beat note, and high sensitivity is attained. In addition, since a large number

Fig. 4. Details of search head, including L_2 , C_5 , and C_6 . L_2 should be bunch wound with 50 turns 36 s.w.g. e.s.c. wire, tapped at 10 turns, and varnished. The 3-core cable should be about 5 ft long—screened cable should not be used.

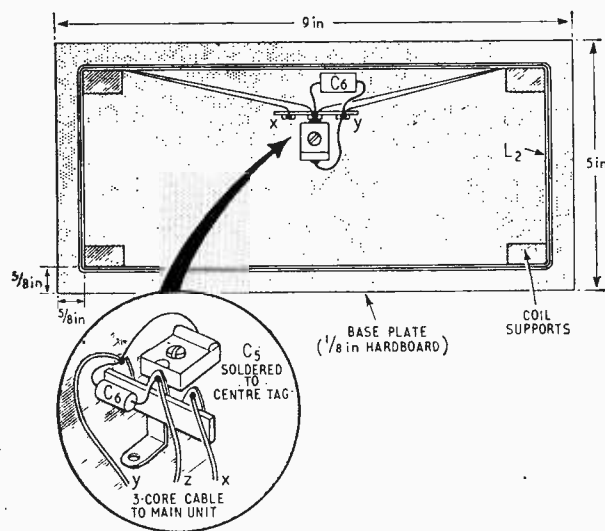

of usable harmonics is available, no great care is required in either designing or constructing the circuitry to operate at some precise frequency.

Circuit description

The complete circuit of the unit is shown in Fig. 2. Here, Tr1 is wired as the fixed frequency oscillator, with tank coil L_1 centre-tapped to give the necessary phase-reversal required for oscillation, and tuned by C_1 . Tr2 is the variable frequency oscillator, with its centre-tapped tank coil, L_2 , built into the search head and tuned by C_3 , C_6 and C_5 ; C_8 is built into the main part of the unit, and enables the operating frequency to be varied by a small amount during operation.

The output of Tr1 is taken from the emitter, at low impedance, and is fed *via* C_1 and R_7 to the detector diode; similarly, the output of the variable frequency oscillator is taken from Tr2 emitter and fed *via* C_9 and R_8 to the same diode. The resulting signal is then filtered by R_9 , C_{10} and fed to the a.f. amplifier. It should be noted that R_7 and R_8 are used as buffer resistors to minimize pulling between the two oscillators; if these were not used, the two oscillator signals would tend to lock to one another, and it would not be possible to obtain low frequency beat notes.

Use

When using the unit, the beat note can be set so that the frequency either increases or decreases in the presence of metal, depending upon which side of the "null" point the variable capacitor, C_8 , is set. It must be remembered, however, that a certain amount of interaction takes place between the two oscillator circuits, and if the unit is set to give a very low frequency beat signal, of the order of a few tens of c/s, the two oscillators tend to pull together and lock to one another's frequencies, so that the beat frequency falls to zero. For this reason, it is preferable to set the unit so that the presence of metal is indicated by a rise of beat frequency.

When construction of the unit is complete, C_8 should again be set at half-mesh, and C_5 should be adjusted to obtain near-zero beat in the absence of metal. It should be noted that a large number of beat notes can be selected by adjusting C_5 , and this capacitor should be adjusted to tune in to the strongest beat note that is available. Any further adjustments of frequency can now be made on C_8 . (In practice, a larger value of C_5 or C_6 may be necessary.)

"W.W. Diary"

THE 80-page reference section of the 1967 *Wireless World* Diary gives in tabloid form technical and general information one so often needs but is seldom readily available. The contents of the reference section goes from abbreviations and addresses of organizations through frequency allocations and licence regulations to transistor near equivalents and world television standards. In addition there are, of course, the week-at-an-opening diary pages. It costs 7s 6d (leather) or 6s (rexine).

LETTERS TO THE EDITOR

The editor does not necessarily endorse the opinions expressed by his correspondents

Multivibrators

FURTHER to Mr. J. R. Chew's article in the September issue on obtaining good square waves from a multivibrator, I would like to mention a simple modification to the basic circuit which gives a sharp edged square wave with a slightly sloping top.

As Mr. Chew points out, with the basic multivibrator, the leading edge of the square wave is rounded because the collector is held down by a capacitor to the opposite base. If a resistor is connected in series with the capacitor this restriction is removed and the collector voltage rises, as fast as the transistors can switch, to a voltage dependent on the values of the collector and capacitor resistors. Thereafter it continues to rise, more slowly than before, to its full value. A convenient value for the capacitor resistance is the geometric mean of the collector and base resistances, when, for typical transistors, the collector voltage will rise to 70 or 80% of its final value.

A disadvantage of this type of circuit is that if the supply is switched very rapidly to its full value both transistors bottom indefinitely. This does not happen in the basic multivibrator provided the transistors have adequate gain at $V_{ce}=0$ but it will happen with both Mr. Chew's modified circuits. A certain method of preventing this is shown on page 530 of the October issue. Another method, which avoids extra loading on the collectors, is to connect the base resistors to the supply through a resistor decoupled to earth. After switch-on the base currents build up slowly and the transistors are unsaturated for long enough for the strong instability of the circuit to tip it one way or the other.

Stewart and Lloyds Ltd., G. C. A. TALBOT,
Corby, Northants. (Control Systems Section).

AS Mr. Chew pointed out in his article "Multivibrator Design Difficulties" one of the common methods for correcting the waveform of the basic collector coupled multivibrator is that shown in Fig. 1. The obvious effect of the inclusion of D_1, R_2 and D_2, R_5 is to isolate the exponentials on C_1 and C_2 from their associated collectors during the off times of each transistor. The result is a clean edged waveform at each collector.

There is however another less obvious effect resulting from the inclusion of D_1 and D_2 . Provided certain conditions are fulfilled, the modified circuit exhibits an improvement in timing stability compared with the basic arrangement. This interesting aspect was originally pointed out by Dodgson¹, although the inclusion of the

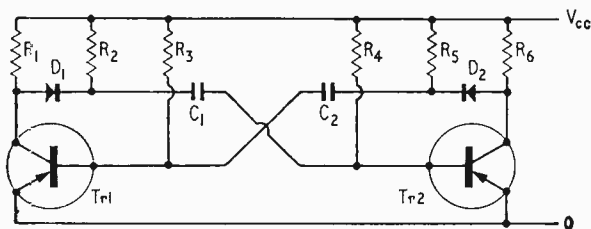

Fig. 1. Waveform corrected, a stable multivibrator.

isolating diode waveform corrector is generally attributed to Rozner².

If we select suitably stable passive components in the timing network, the timing stability depends chiefly upon the leakage currents of the transistors, and the variation of base-emitter voltage and bottoming voltage of Tr1 and Tr2. The problem of the transistor leakage currents can be solved, of course, by using silicon transistors. A departure from the well known ideal timing equation occurs if the effect of the V_{be} is taken into account—the influence becoming more marked at low supply voltages. In addition the base and emitter voltages are temperature dependent, and thus compared with the variation in saturation voltage they have the predominant effect on timing stability. It would seem that if their effect could be lessened one might reasonably obtain a substantial improvement in timing stability. A simple analysis of Fig. 1 does in fact show that the inclusion of the diodes helps to achieve this aim.

Initially assume that Tr1 has just become saturated, then if we neglect the bottoming voltage, the collector goes from $-V_{cc}$ to zero. The cathode of D_1 thus goes from $-V_{cc}$ to $-V_d$, where V_d is the forward voltage drop of diode D_1 . This voltage step is transferred to the base of Tr2 via C_1 and makes it go $[V_{cc}-V_d-V_{be}]$ volts positive with respect to zero. The base of Tr2 now starts to go negative on its appropriate time constant. The maximum swing it could go through is $[2V_{cc}-V_d-V_{be}]$ but as we know Tr2 conducts when the swing has risen by $[V_{cc}-V_d]$ volts. Fig. 2 should make this

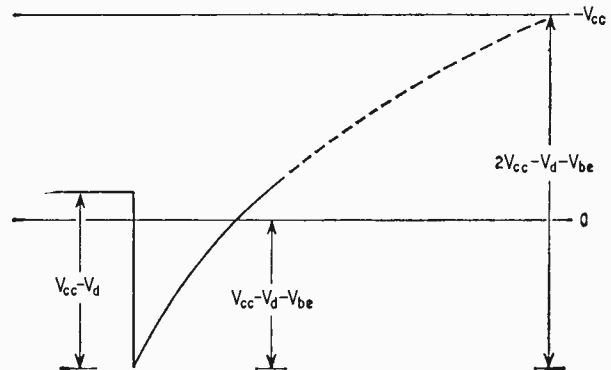

Fig. 2. Base waveform of Tr2 during "off" period.

point clear since it shows the base waveform of Tr2 with the levels marked in.

Let us use the well known formula $V' = V \exp\left(-\frac{t}{RC}\right)$ where t is the timing period, V' is the voltage swing during this time and V is the maximum available voltage swing.

Since RC is constant and we want t to be constant then V' must be constant.

From Fig. 2
$$\frac{V'}{V} = \frac{V_{cc} - V_d}{2V_{cc} - V_d - V_{be}}$$

Ideally, if $V_d = V_{be}$, t becomes independent of the supply voltage giving $\frac{V'}{V} = \frac{1}{2}$.

By applying a similar analysis it is not very difficult to show that in order to remove the temperature dependent effect of the V_{be} on timing stability then $\Delta V_{be} = \Delta V_d$.

In practice it would appear that with only random selection of the diodes one can expect a considerable improvement in the timing stability of these type of circuits.

I have not had the opportunity of performing measurements on a practical circuit but Dodgson¹ publishes convincing curves for the improvement in timing stability of a diode assisted monostable multivibrator against its conventional counterpart.

It would seem that this circuit is quite a versatile and economic arrangement having a little more to it than meets the eye.

Cheadle, Cheshire.

M. HARDING

1. "Improved Multivibrators", P. Dodgson, *Electronic Eng'g*, Vol. 35, No. 423 (1963).
2. F. Rozner, British Patent No. 790/941.

High Performance Transistor Amplifiers

CONGRATULATIONS to Dr. A. R. Bailey on being one of the first to stress, in a British technical magazine, the necessity of output stage protection. However, here are a few remarks:—

(1) *Phase splitting*.—Coupling transformers are not the only simple solution. The use of a complementary pair of transistors is another. A glance at recent American, Japanese, German, French and Dutch transistor amplifiers indicates that manufacturers use less and less coupling transformers. Manufacturers such as Dynaco and Mc Intosh, who built their reputation making audio transformers, now produce transformerless transistor amplifiers!

(2) *Distortion*.—It would be interesting to see distortion curves from zero to full power, as it would indicate whether crossover distortion has been eradicated (this would happen below 5 W output—Fig. 8).

(3) *Output impedance*.—One would like to know whether the amplifier can be used with 4 to 16 Ω speakers, and what are its performances at 4 and 8 Ω .

(4) *Overload recovery*.—This is also an important characteristic of audio power amplifiers, and it is useful to know the behaviour of a power amplifier when overloaded.

Brussels, Belgium.

L. GILLAIN

The author replies:—

I was interested to read M. Gillain's letter and would like to reply to his comments in order.

1. The phase splitter design in transistor amplifiers is not very easy if balanced drive is to be obtained for the output transistors. Using the more normal quasi-complementary system for driving the output transistors, a considerable degree of asymmetry normally results. Rather than use expensive matched transistors, it was felt better to use the driver transformer approach.

2. Regarding the distortion of the amplifier, I am appending a graph of its variation with output power. The crossover distortion is virtually non-existent and at levels below 1 W output, the distortion level is very small indeed.

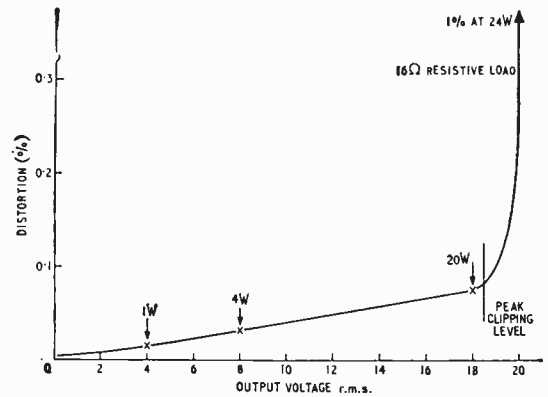

3. The amplifier can be used with lower impedance loudspeakers; the power output at 8 Ω will be somewhat reduced using the present circuit, and for a 20 W amplifier a small revision of component values would be necessary. For driving into 4- Ω loudspeakers, it would be better to use a 2-1 step down transformer to drive the loudspeaker as otherwise a complete re-design of the circuit would be necessary.

4. The overload recovery of the amplifier is quite adequate; a photograph showing the effect of high frequency overdrive appeared in last month's issue (p. 613). The performance at low frequencies is very similar, there being only slight overshoot when the overload is removed.

A. R. BAILEY

Noise in Transistors

MOST treatments of noise in transistors begin by presenting an equivalent circuit liberally sprinkled with generators which may or may not be correlated. For ordinary mortals a few simple ideas may be more useful.

Consider a common-emitter amplifier in which flicker, frequency and leakage effects are neglected. Then assume that the following sources of noise are important.

(i) Johnson noise in the resistance of the generator feeding the amplifier and in the base resistance of the transistor.

(ii) Shot noise on the base current which produces a voltage across the generator and base resistances in parallel with βR_e (the input resistance— R_b) that then

Noise figure F against generator resistance R_g for shot noise in an NKT142. $\beta = 67$; $R_b \sim 150\Omega$; $I_e = 0.54\text{mA}$, $V_{ce} = 6\text{V}$.

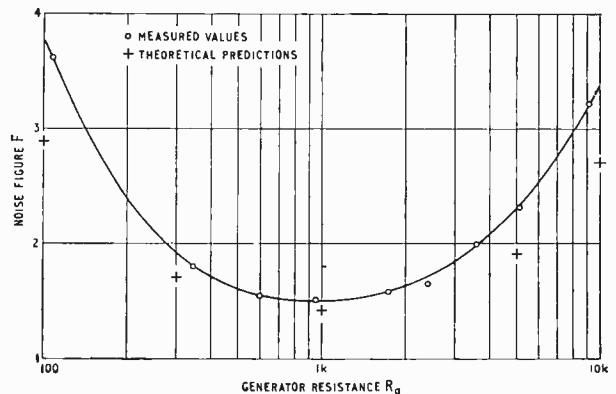

remodulates the emitter current via the mutual conductance of the transistor.

(iii) Shot noise of the collector current.

Then the mean square fluctuation of the collector current is given by:—

$$4kT(R_g + R_b) \Delta f \left(\frac{\beta R_c}{\beta R_e + R_b + R_g} \right)^2 a^2 g_m^2 + 2eI_b \Delta f \frac{(R_g + R_b)^2 \beta^2 R_c^2}{(\beta R_e + R_b + R_g)^2} a^2 g_m^2 + 2eI_c \Delta f$$

where k = Boltzmann's constant; T = absolute temperature; Δf = bandwidth; e = electronic charge; R_b , R_g , R_c = base, generator and emitter resistances; $g_m = \frac{I}{R_e} = \frac{eI_c}{kT} = \frac{I_c}{25}$ (in mA); and $\beta = \frac{\alpha}{1-\alpha}$ = common emitter current gain.

The contribution from Johnson noise in the generator resistance is given by the first half of the first term, dividing by this gives the noise figure F .

$$F = 1 + \frac{R_b}{R_g} + \frac{\alpha(R_g + R_b)^2}{2\beta R_g R_e} + \frac{(\beta R_e + R_b + R_g)^2}{2\alpha \beta^2 R_e R_g}$$

F was measured for an NKT142 using a noise diode and a frequency band extending from 10 to 30 kc/s. The results are shown on the graph together with predictions from the formula. The agreement is satisfactory, the predictions being about 2 dB below the measured values. It is interesting that Neilsen's formula* also predicts values about 2 dB low. These ideas were stimulated by a discussion with R. P. Gifford.

Clarendon Laboratory,
Oxford.

GUY PESKETT

*Nielsen, E. G., *Proc.I.R.E.*, 45, 957, 1957.

Another Simple Low-voltage Receiver

THE receivers described by G. W. Short and G. Wareham in your issues of October and November respectively, while laying no claim to merit for serious listening, raise some points of circuit design which I am sure have greatly interested your readers. Some years ago I experimented with receiver designs for casual listening and evolved the circuit shown in the diagram.

The success of the r.f. portion is dependent on the fact that with modern high β transistors the gain of a resistance-capacitance stage of suitable design can approach that of a fully neutralized stage although, of course, selectivity is lacking. A tuned stage can be shown to

have a maximum power gain $\beta^2 n^2 / 4$ where $n = \sqrt{[r_o/r_i]}$, $r_o = r_e / 2\mu$, and $r_i = \beta r_e / 2$, r_e and μ being the usual T parameters. Thus the optimum tuned power gain is $\beta / 4\mu$. For an untuned stage, when the input impedance r_i of the following transistor is considerably less than r_o or the collector load R_L , the power gain is substantially β^2 since, by the above loading conditions, reverse voltage feedback is negligible. Thus the ratio (tuned gain)/(untuned gain) = $4\mu\beta$ which is unity for $\beta = 500$ approximately, for a typical value of μ . Among the r.f. transistors used in my design it was easy to find specimens with β greater than 300; nowadays using low current planar types one can do even better. The choice of working current is largely a matter of optimizing for β .

Finally, I should like to comment on two other features of this design which may be of interest: the detector is a transistor whose action is analogous to that of a leaky grid valve detector and gives substantial gain: the resistor R_1 serves both to sensitize this detector by biasing Tr3 to near turn-on, and to provide about 10dB feedback. Since your contributors have dwelt on current consumption, I should add that the quiescent current is 10-15mA, rising to 25mA during average listening and 30-40mA during very loud passages.

Cavendish Laboratory,
Cambridge.

N. BETT

Constant-current Circuits

MAY I express my thanks to Baxandall and Mr. Rudge for their comments in the December issue on the constant current circuit described in my earlier letter (September p. 456). The points they raise form a cogent summary of the characteristics peculiar to this circuit (or should I say "of this peculiar circuit?").

Mr. Baxandall suggests that positive feedback should not be invoked to explain the operation of the circuit. I have found that it helps some students to approach it via the well-known complementary bistable, having first derived the conditions under which positive feedback results in switching. The possibility of a second stable state in which both transistors are non-conducting is then apparent. I certainly agree with his comments on its performance in the conducting state, and would only add that the negative temperature coefficients of the Zener diodes provide approximate compensation for the V_{be} drifts. High gain silicon planar transistors would reduce the importance of gain and leakage variations with temperature.

The use of a resistance between the emitters, as Mr.

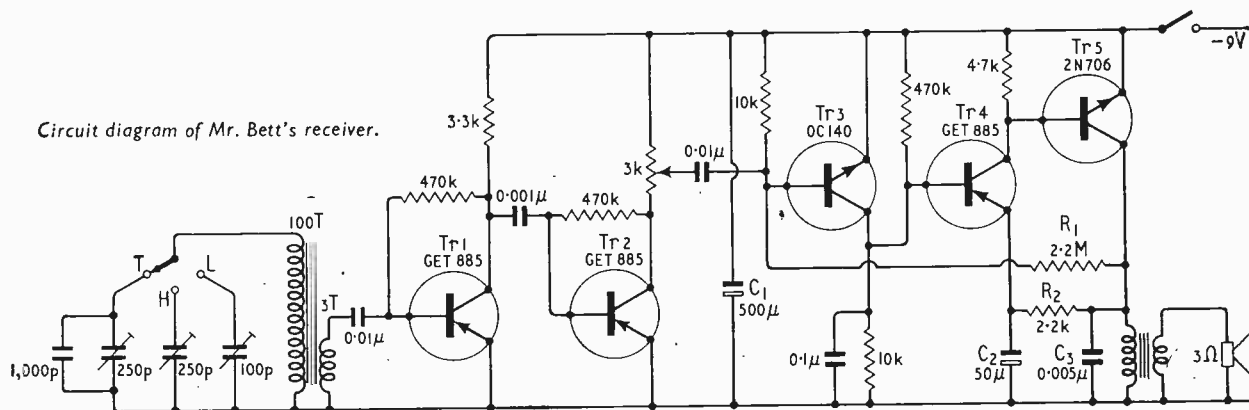

Rudge clearly shows, provides compensation for supply variations. Having used this method I can confirm that a very high order of stability can be achieved. A variation in current of less than 1% was observed for a 10:1 range of supply voltages in one version of this circuit. The negative resistance that results from over-compensation leads to a simple, though rough and ready, tunnel diode analogue, with voltage levels large enough for laboratory demonstrations of tunnel diode circuits at low frequencies.

Paisley College
of Technology,
Renfrewshire.

PETER WILLIAMS

Electronic Probability Distribution Models

RECENTLY I have had occasion to consider the effects of differentiation upon overload conditions of electronic machines with their mechanical analogies. These conditions which have been under consideration approximate to the curve of distribution functions derived mathematically from the postulates of Bernoullian Probability. This means that a rise in say d.c. conditions to overload point and thus to saturation of the circuitry involved if plotted against time can be in many cases normalized to a standard distribution function. Considerable study was undertaken in order that these overload conditions could use the already existing mathematics of probability theory. A common overload device is a simple RC differentiation circuit that will find any increase in conditions and hence upon differentiation will supply a pulse in order to trigger protective devices.

The practical difficulty arises from overshoot of the derived pulse, thus negatively actuating the overload protection device. In order to study this problem practically, it was thought that, using a square wave generator and suitable time constant filters, various shapes of wave could be produced which upon differentiation could be displayed upon an oscilloscope. The maximum amplitude and time constant of fluctuation corresponding to the critical point of zero ringing could be found. This method would enable the designer to see probable responses of systems under various overload conditions without going through the tedium of mathematics previously necessary for such an analysis. In other words it was thought that

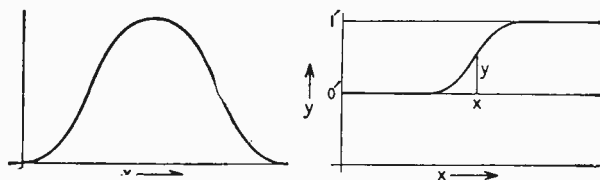

Fig. A.

it would be possible to consult an electronic curve finder instead of the linear and not so feasible extrapolations previously necessary.

No experimentation has been carried out with the above but it is hoped to do so in the near future. Further consideration upon this subject has brought forward an idea to electronically construct probability distribution curves using the above equipment. In other words when a distribution is experienced the wave of the distribution function giving rise to the corresponding frequency function could be found by matching derived oscillographs with the found distribution, hence allowing the distribu-

tion function to be analyzed by an oscilloscope. It is realized that in practice the square wave thus altered would give rise to two pulses but adequate synchronization of oscillator and oscilloscope would give the desired result. Using a timebase stretching system even analysis of tails would be possible.

The application of the distribution function allows the probability at any ordinate to be reduced to a measurement of the Y ordinate of this curve. For example, suppose a distribution is found upon statistical analysis to be as in Fig. A. The curve to be the nearest fit is found by comparing oscillographs.

Then a translation of axes and normalization of the Y curve would give on direct measurement the probability of the event X.

A further possibility would be to use a scanning system scanning at appropriate intervals along the X axis and being returned to the base line O' B' when synchronized by the voltage derived by the effect of the trace of the distribution function. Such a system could operate on a time lapse measurement of ordinate to print out the required possibilities for each scan value of X. This would reduce the analysis of statistical results to plotting the found results, then matching them with a time constant control and then waiting whilst the machine prints out the probability estimate for each scan point of X, thus reducing the problem of curve analysis to a simple drawing of results in discrete form and then fitting the best continuous curve with the available time constants.

Wellington,
New Zealand.

G. H. RAILTON

Bass-reflex Enclosures

THE general physical principle and the advantage of a bass-reflex enclosure for loudspeakers for sound-reproduction have been discussed numerous times in different journals, e.g., refs. 1, 2. However, if one contemplates the actual construction of such a device for a given type of speaker, very little pertinent information seems to exist. Innumerable descriptive articles can be found but most of these are based half on theoretical and half on experimental data with very little experimental evidence to rely on.

Searching the literature one very fundamental study by a German physicist published in an American periodical came to light.³ The article seems to have been overlooked by authors of constructional articles with apparently one exception⁴.

Starting from the basic differential equations for the description of the behaviour of the electrical-acoustical transducer Keibs³ derived a complete equivalent circuit and the optimum values for different parameters. He discussed the steady-state situations as well as the optimum damping to obtain the best transient response. Although the author did not intend to give a "cookery-book recipe" careful reading reveals that strikingly simple expressions can be extracted with relation to actual construction and also to testing. This may be summarized in its simplest form as follows:

1. The Q -value of the resonant circuit of the speaker only at the free-field resonance frequency f_0 should be $Q = 0.83$ for constant radiated power down to the lowest possible frequency. Given a speaker with its cone construction, voice-coil resistance and air-gap induction this value can be adjusted only by changing the amplifier's output impedance by feedback arrangements. Alternatively the proper damping may be acquired by the

application of absorbing material at the back of the speaker frame.

2. The ratio of the stiffness of the air in the enclosure (with the duct closed) to the stiffness of the speaker-cone suspension should have a prescribed value related to Q . This is easily to be verified by measuring f_0 (in c/s) of the speaker only and the resonance-frequency f_1 of the speaker mounted in the enclosure (duct closed). The correct ratio is:

$$\frac{f_1}{f_0} = 1.56$$

The enclosure with open duct resonates at f_2 equal to f_0 . The frequency f_2 is related to f_1 by the Q -factor resulting in the optimum value V :

$$V = 24800 \times \frac{A_1}{(f_0)^2} \text{ (in cm}^3\text{)}$$

Here A_1 is the ratio of the effective cone area squared to the effective cone mass. Now this factor A_1 can be determined as one quantity by loading the front of the speaker cone with an hermetically closed volume V' of reasonable size (e.g. 15,000 to 50,000 cm³). The resulting resonance frequency f'_1 is of course again higher than f_0 (for high-compliance speakers quite appreciably). A derivation from the above formula results in:

$$A_1 = 27,77 \times 10^{-6} \times \{(f'_1)^2 - (f_0)^2\} \times V' \text{ (in cm}^3\text{/g)}$$

with V' in cm³.

3. The ratio of A_1 (for the cone) to A_2 (for the reflex diaphragm) is again related to speaker Q -value. This results in an expression for the length l of the duct:

$$l = 3778 \times \frac{(R_2)^2}{A_1} - 1.7 R_2 \text{ (cm)}$$

where R_2 is the radius of the duct in cm; l and R_2 are to be chosen within dimensionally reasonable limits.

The above formulae would theoretically result in a power vs. frequency characteristic which is virtually flat with a half-power point very close to f_0 . This is about 70% of the -3dB frequency of the optimum response obtainable with the same speaker in a closed box. The slope of the former response will be about 19 dB/octave. In spite of this the transient response is such that "ringing" should be subjectively unnoticeable as the Q -value has a magnitude below the limits as determined by other research work.

Although Novak does not refer to Keibs' work his nomograms are obviously based on it. Novak's article suggests that the method outlined above is more or less universally applicable. A quick test with a cheap 6in high-compliance speaker that happened to be at hand indicated an optimum volume which was much smaller than would have been considered "normal." With the present-day tendency to very small (closed) volumes for loudspeaker enclosures it would be interesting to know if the outlined procedure could be a guide to better founded and more satisfying home constructions without undue limitations to the power delivered by small, high-compliance loudspeakers.

Voorschoten,
Netherlands.

B. C. REITH

REFERENCES

- (1) "Vented loudspeaker cabinets," C. T. Chapman. *Wireless World*, Vol. 55 (1949), p. 398.
- (2) "Loudspeaker enclosure design," E. J. Jordan. *Wireless World*, Vol. 62 (1956), pp. 8 and 75.
- (3) "The physical conditions for optimum bass-reflex cabinets," L. Keibs. *Journal of the Audio Engineering Society*, Vol. 8 (1960), p. 258.
- (4) "Designing a ducted-port bass-reflex enclosure," J. F. Novak. *Electronics World*, January, 1966, p. 25.

LITERATURE RECEIVED

"Industrial Cathode Ray Tubes 1966," a 16-page Brimar guide outlines the new tube nomenclature for Brimar tubes screen phosphors and equivalents, radar and compass tubes, (radio d.f. applications), oscilloscope tubes (single and double gun), demonstration and monitor tubes. There is also a classification index. Thorn-AEI Radio Valves and Tubes Ltd., 7 Soho Square, W.1.

WW 328 for further details

"Modular High-Fidelity Loudspeaker Systems and Driving Units" is a 5-page product bulletin by Jordan-Watts Ltd., Benlaw Works, Silverdale Road, Hayes, Middlesex. It contains information on available enclosure systems, constructional data on 12-W and 25-W reflex enclosures, and installation notes.

WW 329 for further details

Technical data sheets on silver metallising preparations for refractory materials have been issued by Johnson Matthey & Co. Ltd., 78-83 Hatton Garden, London, E.C.1. Intended for applications such as ceramic capacitor discs, mica capacitor plates, crystal oscillators, and piezo electric transducers, the technique is described in the 4-page Electrical Engineering Data sheet 1300-472: firing, covering power, electrical properties, methods of application and soft soldering are mentioned in this sheet.

WW 330 for further details

A range of die-cast aluminium housings developed to provide r.f. shielding for small groups of components in such applications as attenuators, filters, networks, voltage dividers, etc., is described in leaflet N1/10/66, from Hatfield Instruments Ltd., Burrington Way, Plymouth, Devon.

WW 331 for further details

Engineering Information Report 204 by International Rectifier Co. (G.B.) Ltd., Hurst Green, Oxted, Surrey, is in fact a 67-page handbook on thyristors plus a 25-page data section. It includes definitions and terms, static and dynamic characteristics, rating and associated data, series and parallel operation, voltage and current protection testing, and applications of thyristors. It is available at a cost of 30s, which includes a supplement service.

Data sheet 238-A entitled "Potentiometer Slave Units and Indicators" discusses a simple means of energizing current operated loads from the output of potentiometer type displacement transducers, pressure transducers, and accelerometers. Specific applications and three types of slave unit are described in the data sheet issued by Intersonde Ltd., The Forum, High Street, Edgware, Middlesex.

WW 332 for further details

The difficulties and problems peculiar to the measurement of nanosecond and subnanosecond current pulses are considered in a 4-page reprint from Tektronix U.K. Ltd., Beaverton House, Station Approach, Harpenden, Herts. Current transformer requirements, and the transformer versus the non-reactive resistor are discussed under the title "Current Measurements at Nanosecond Speeds."

WW 333 for further details

From the Molecular Electronics Division of the Westinghouse Electric Corporation comes a 7-page quick reference guide 9100 to digital and linear integrated circuits. The functions and design features of each circuit are fully described in this guide received from the U.K. agents Voice and Vision Ltd., 26 Upper Brook Street, London, W.1.

WW 334 for further details

"Micronotes" Vol. 4, No. 3, published by Microwave Associates Inc., Burlington, Massachusetts, U.S.A., is concerned with the measurement of noise in solid state microwave sources. The origins of f.m. and a.m. noise, measurements, and the basic noise measuring equipment are dealt with.

WW 335 for further details

Video Disc Recording

VARIOUS systems for recording video information on disc have been suggested in the past, but none of these appears to have succeeded in becoming commercially viable. Another system was demonstrated recently in Wolverhampton by C. J. Mason, of Video Records Ltd. In its present form this system (the subject of British and foreign patents applied for three years ago) provides for the recording of video information on the periphery of a 10-in disc. The video disc is cut from a sheet of suitable photographic film, on which the video signal is recorded in photographic form. A 7-in audio disc can be placed on the same turntable as the video disc, and the two signals synchronized.

The video information from the television camera is used to frequency modulate a carrier of 6 Mc/s to a maximum deviation of ± 4 Mc/s. The signal is then subjected to half-wave clipping, and the result is squared, shaped and fed to a monostable multivibrator. The pulse train is then mixed with peak white and peak black pulses (these having been clipped off the modulation video signal at predetermined levels prior to modulation), and the composite signal fed to the recording

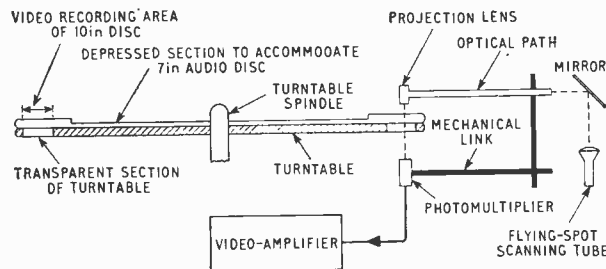

The principle of playing back the disc-recorded video information. In the photo below the picture on the television screen is derived from a video disc.



video amplifier, and recorded onto the photographically sensitive 10-in disc. Because of problems connected with the present emulsion, such as grain size and clumping, the result is a form of gradual density modulation and not discrete pulses as intended; however it is stated that the use of non-continuous tone emulsions greatly improves the reduction of video noise, and grain is non-existent. One method described for frame and line synchronization is to incorporate a separate sync pulse disc into the player. An accuracy (between successive line pulses) of $\pm 1 \mu\text{s}$ is said to be easily obtainable from such a sync disc used in conjunction with a photo-transistor.

The present method of playing back the recorded video signals is shown in the diagram. The light from the flying spot tube scans the recorded area of the 10-in disc; the light is intensity modulated by this process and passes through the transparent section of the turntable to a photomultiplier and the resulting signal is then fed to a video amplifier and display. Although the resolution of this system has not yet reached an acceptable standard, work is continuing on the development of this approach to video recording.

BOOKS RECEIVED

Radio Remote Control and Telemetry and their applications to missiles, by Jean Marcus. Modulation, coding of control information, effects of noise, jamming; systematic errors and distortion, aerials, complete control and telemetry systems, automatic pilots are all discussed. This book, as well as being of interest to engineers wishing to study the subject, should be of use to experimenters in the radio control of models. Pp. 258. Price 70s. Pergamon Press, Headington Hill Hall, Oxford.

Electrical Phenomena in Gases, by R. Papoular (translated from French by B. Jeffrey and edited by Dr. D. L. Jones). This book assumes a knowledge of mathematics to about degree standard and is designed to be of use as a reference work and a means of study. Starting with a review of the structure of matter leading up to a study of basic reactions among sub-atomic, atomic and molecular particles, and the derivation of macroscopic characteristics of gas from microscopic parameters, this book concludes with a section on plasma diagnostics. Pp. 198. Price 45s. Iliffe Books Ltd., Dorset House, Stamford Street, London, S.E.1.

Computer Dictionary, by Charles J. Sippl. Of particular use to those concerned with operating, programming teaching or studying computers this book lists over 5,000 definitions. Its 20 appendices contain discussions on mathematical and statistical definitions, number systems, computer languages, acronyms and other related subjects. Pp. 336. Price 40s. W. Foulsham & Co. Ltd., Slough, Bucks.

Electrical Insulation Measurements, by W. P. Baker. Aimed at the industrial laboratory worker with a degree or H.N.C., this book starts with a description of the physical and chemical nature of insulating materials and the mechanisms of dielectric breakdown. Chapters cover measurement of dielectric loss, special techniques for liquids and tests on complete equipments. Pp. 180. Price 50s. George Newnes Ltd., Tower House, Southampton Street, London, W.C.2.

Outline of Radio and Television, by J. P. Hawker. A useful non-mathematical introduction to radio and television. Early chapters cover fundamental theory leading up to a description of the operation of valves and transistors. Amplifiers, radio receivers, tape recorders, monochrome and colour television are all discussed at some length. A chapter on stereophonic sounds includes a description of the Zenith/G.E. (Pilot-tone) system of stereo broadcasting. Pp. 399. Price 30s. George Newnes Ltd., Tower House, Southampton Street, London, W.C.2.

DATA TRANSMISSION DEMONSTRATIONS

CIRCUITS FOR SHOWING THE PRINCIPLES OF FREQUENCY-DIVISION
AND TIME-DIVISION MULTIPLEX SYSTEMS

By N. M. MORRIS,* B.Sc., A.M.I.E.E., A.M.I.E.R.E.

MANY industries are using various forms of data transmission as the basis of control, monitoring and alarm systems. There is consequently a need to educate people in these techniques, and in this article the author presents some relatively simple units, designed for demonstrating frequency-division and time-division multiplexing to technical college students. Readers may feel that some of the electronic circuits could be simplified by the use of more advanced techniques, but these are beyond the grasp of many students and the author feels fully justified in using the circuits outlined. The systems are limited to on-off applications to restrict their complexity.

FREQUENCY-DIVISION MULTIPLEXING

Fig. 1 shows the basic principle of f.d.m. The input data at frequencies f_1, f_2, f_3 etc. are added in a simple linear network, the output being $k(f_1 + f_2 + f_3 + \dots)$ where k is a numeric. At the receiving end the signal is demodulated linearly to give an indication of the signals present at the input. At the outset it was decided to show by visual indication if a signal was or

was not present rather than monitor the output on meters. If metering is required the output from the filter circuits can be measured by a valve voltmeter.

Mixing circuit.—Three audio frequency inputs are used in the demonstration equipment, shown in Fig 2, the frequency difference being sufficient to ensure that they can be filtered by simple circuits at the receiving end. The adding circuit is a useful educational aid in itself to show the principle of linear frequency mixing using star-connected resistors.

Filter circuits.—A block diagram of the demodulator is shown in Fig. 3. In order to ensure isolation between the various stages, each filter is supplied from an emitter follower circuit, details of which are given in Fig. 6(a).

Simple RC filter circuits are used in the equipment to permit the use of elementary filter theory in describing its operation to students. The circuits are shown in Fig. 4.

Visual indication.—For demonstration purposes visual indication is advisable and the method adopted is shown in Fig. 5. The output from each filter circuit is rectified

* North Staffs College of Technology.

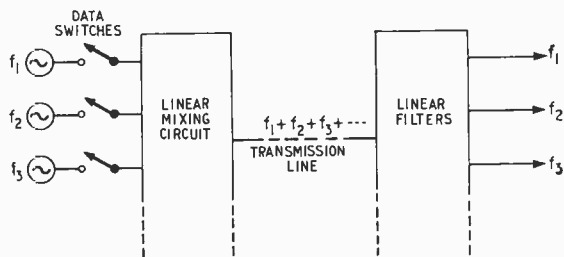

Fig. 1. Principle of frequency-division multiplexing.

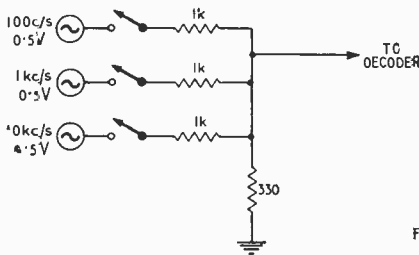

Fig. 2. Linear mixing circuit.

Fig. 3. Block diagram of demodulator.

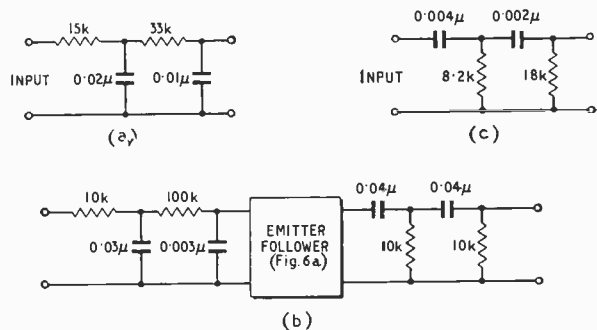
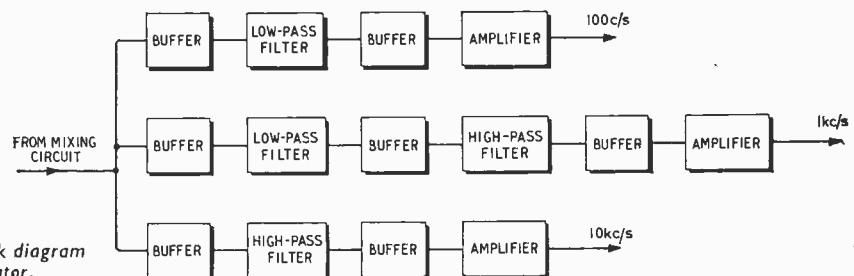

Fig. 4. Filter circuits: (a) 100 c/s, (b) 1 kc/s, and (c) 10 kc/s.

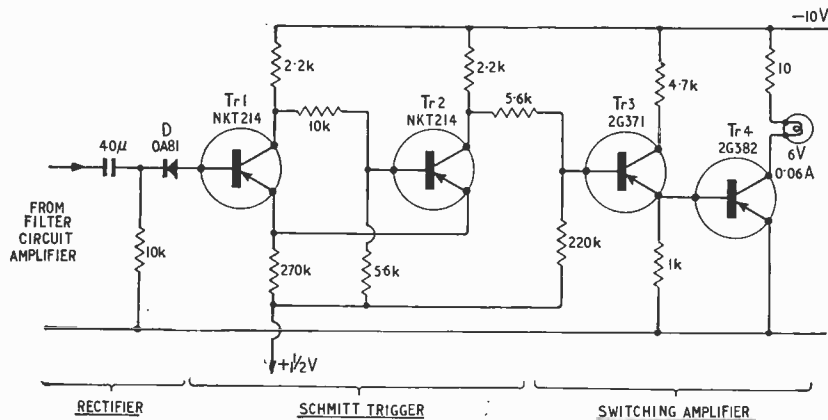

Fig. 5. Lamp drive unit.

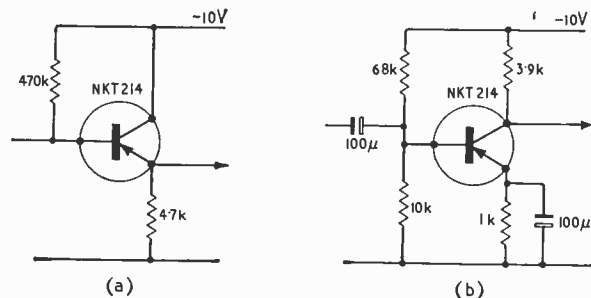

Fig. 6. (a) Emitter follower and (b) amplifier circuits.

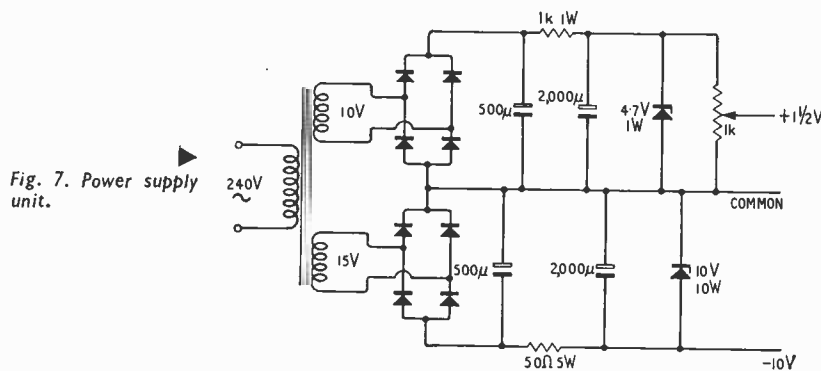

Fig. 7. Power supply unit.

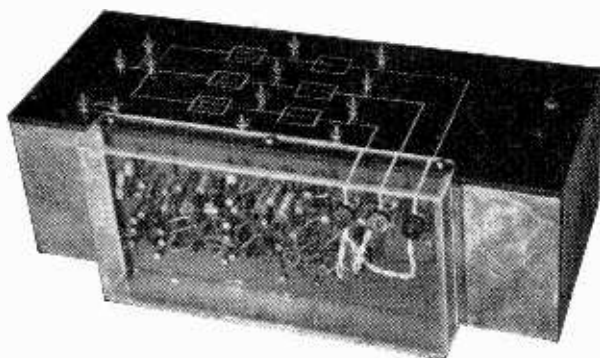

Fig. 8. Completed demodulator.

and fed to a Schmitt trigger circuit which converts the rectified signal into a series of pulses. The pulses drive a switching amplifier, lighting a lamp when a signal is present. Since the repetition rate of the pulses is high the lamp appears to be on continuously when a signal is present. If continuous, rather than pulsed operation of the Schmitt trigger circuit is required, the output from the rectifier should be smoothed.

Circuit details.—The buffer and amplifier stages are shown in Figs 6(a) and (b) respectively. It is necessary at the design stage to ensure that the bias condition for each amplifier is correct, otherwise the circuits are quite conventional.

The filter circuits, even with the buffer amplifiers present, suffer slightly from loading effects and the values of R and C used differ from those predicted by theory. It was found that the values of the components used had to be selected carefully, but once this was done no further difficulties arose.

The output from the filter amplifiers is fed to the circuit shown in Fig. 5. The filtered signal appears across the 10 kΩ resistor, positive voltages to the base of Tr1 being blocked by diode D. The +1½ V rail ensures the correct operation of the Schmitt trigger and switching amplifier circuits.

Power supplies.—The -10 V and +1½ V supplies should be ripple-free to prevent inadvertent operation of the indicator lamps. The total current taken from the -10 V rail is about 0.2 A when all the lamps are on, which is well within the capabilities of a simple Zener diode circuit. The circuit used, which has adequate smoothing, is shown in Fig. 7.

Construction.—The completed receiving-end equipment is shown in Fig. 8. The electronic components are mounted on a piece of Veroboard approximately 9 in × 4 in, but with careful design this size could be reduced considerably. The components are displayed under a Perspex cover to permit inspection by students. The power supplies are mounted at the back of the Veroboard and the +1½ V adjustment is brought out at one end.

TIME-DIVISION MULTIPLEXING

In time-division multiplexing the data switches are scanned sequentially and the information is sent along the line as a series of pulses. In addition to the data a synchronizing signal

is necessary to identify the start of the train of data signals. The synchronizing signal may be combined with the data and separated at the receiving end by a sync separator, or for simplicity a separate synchronizing line can be used. The latter method is adopted in this case.

The scheme outlined in this article uses electronic logic units to scan the data sequentially, a synchronizing pulse being produced in the process. The basis of the system is shown in Fig. 9, the data being represented by the state of the switches (which give either a negative potential or earth potential) shown on the left-hand side of the diagram. The decoding circuit ignores information transmitted along the data line until it receives a pulse from the synchronizing link. When this occurs the decoding unit scans the information coming along the data link sequentially, and if information is present (corresponding to a closed switch at the transmitting end) the appropriate lamp lights at the receiving end.

Shift register.—A series of scanning pulses at the transmitting end are generated using a shift register. This

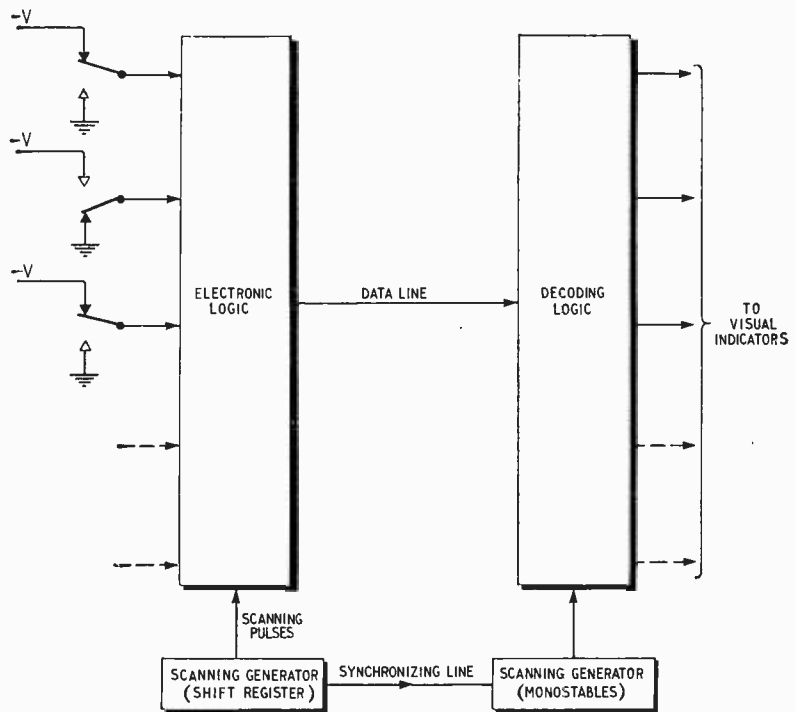

Fig. 9. Principle of time-division multiplexing.

Fig. 10. Shift register for generating scanning pulses in Fig. 9.

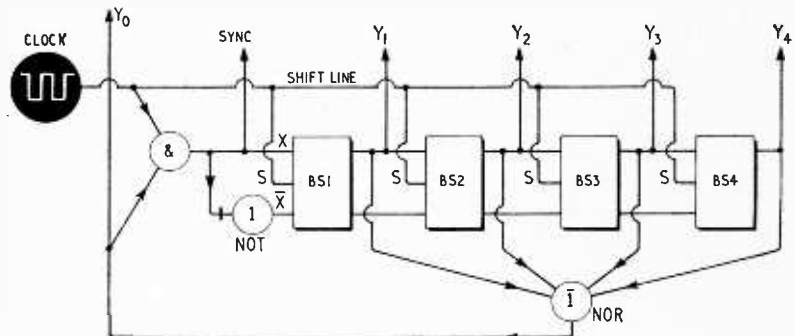

Fig. 11. Transmitter logic block diagram.

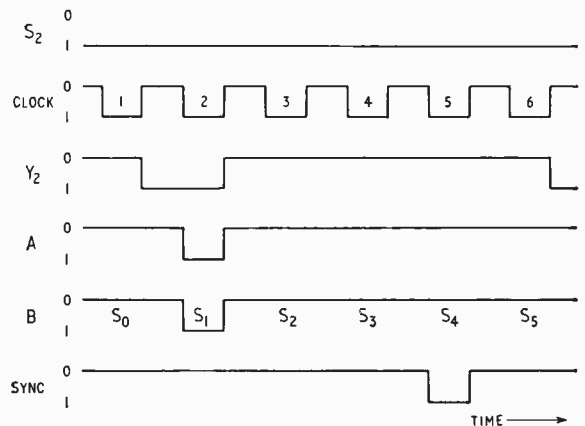
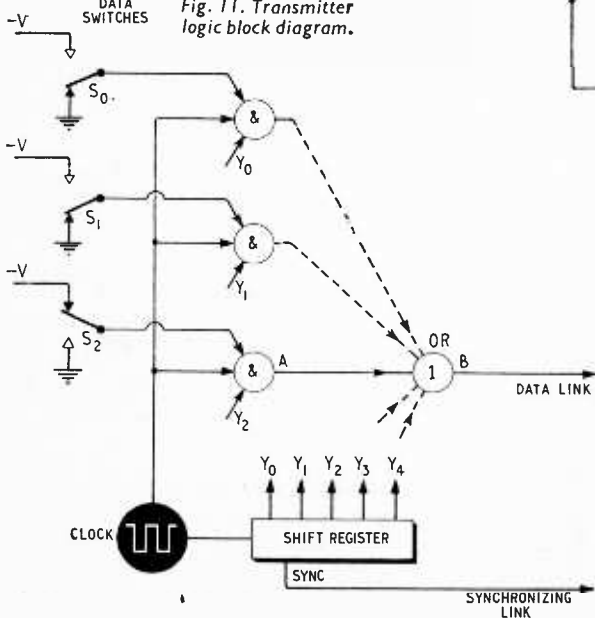

Fig. 12. Transmitting end waveforms when S_2 in Fig. 11 is closed.

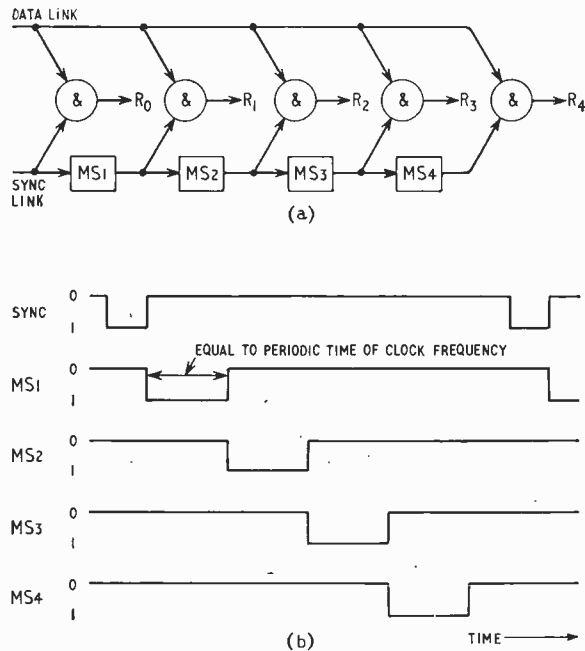

Fig. 13. (a) Decoder logic block diagram and (b) output waveforms from monostable circuits.

comprises four bistable circuits with other logic elements, shown in Fig. 10. Each time the positive going edge of a square wave is applied to the trigger or shift input S of BS1, the voltage at X is reproduced at Y₁, i.e. it is "shifted in" to BS1. By the same means the voltage at Y₁ is reproduced at Y₂ and so on. Thus information in the register is moved along from one bistable to the next at the end of every clock pulse.

The synchronizing pulse for the data transmission system is obtained from the output of the AND gate which gives one pulse per cycle of the shift register when the clock signal and Y₀ are present simultaneously. At the end of the fifth clock pulse the "1" at the output of the AND gate is shifted into BS1, giving output Y₁, which resets Y₀ to zero. This cycle is repeated every five clock pulses. Since the inputs to X and \bar{X} of BS1 must be complementary, the output from the AND circuit is connected to the X input of BS1 and the \bar{X} input is fed through a NOT gate.

Transmitting circuit.—The transmitting circuit is shown in Fig. 11. If S₂ is switched to the negative supply, all other switches being earthed, an output will appear at A, and therefore at B, only when the clock signal and

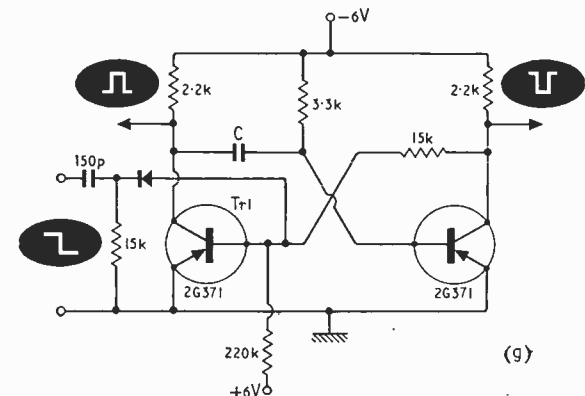
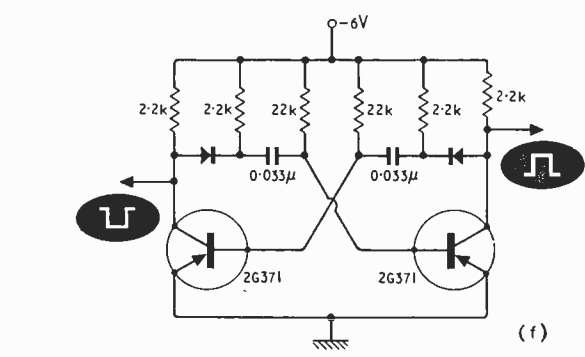
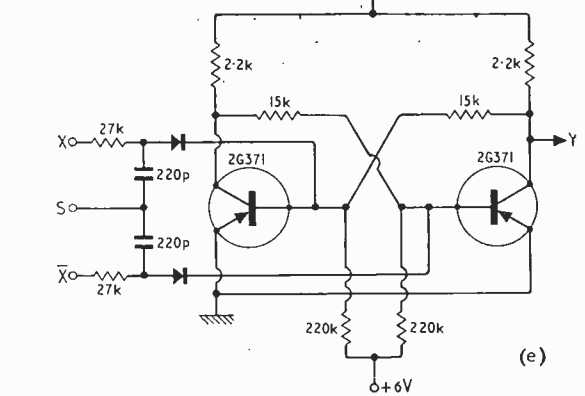
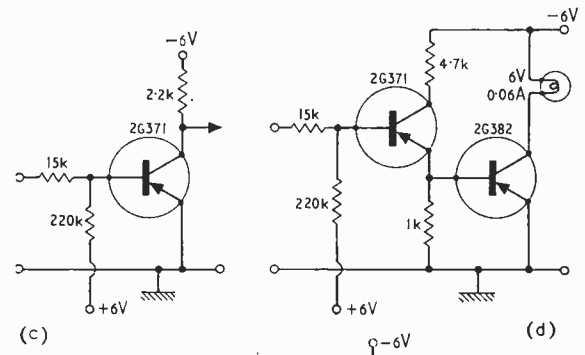
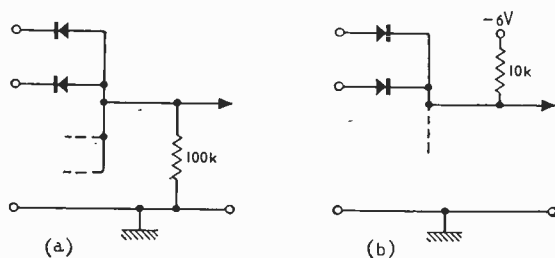

Fig. 14. Logic circuits: (a) OR, (b) AND, (c) NOT, (d) lamp drive, (e) bistable, (f) clock pulse generator and (g) monostable. All diodes are OA81.

Y_0 are present, as shown in Fig. 12. As the "1" in the shift register moves along, it scans the state of the data switches in time sequence.

Decoding circuit.—The decoding circuit, shown in Fig. 13, consists of a number of AND gates, monostable circuits (MS1, etc.) and lamp drive units (not shown). The sync pulse arrives at the same time as the S_0 pulse (see Fig. 12), hence if switch S_0 is closed an output appears at R_0 and the appropriate lamp lights. Since the outputs from all the monostable circuits are zero, lamp drive outputs R_1, R_2 , etc. are zero at this instant.

The trailing edge of the synchronizing pulse triggers monostable MS1 into conduction, its output being a pulse of a duration which is arranged to be equal to the periodic time of the clock pulse generator, shown in Fig. 13(b). This ensures that any pulse appearing at a time equivalent to S_1 (Fig. 12) will give an output from the decoding circuit at R_1 . When the output of MS1 falls to zero it triggers MS2 into conduction, which gives an output at R_2 if a signal is present at S_2 . Each monostable triggers the following one in turn until all outputs are zero when MS4 falls to zero.

The signals travelling along the data link are presented to all the decoder AND gates, but only one of these gates will have an input from the sync line (i.e. the sync line itself or one of the monostables) at any time, giving an output only from the correct AND gate.

Using lamps as the output indicating device and a clock frequency between 1 and 10 kc/s, the repetition rate is high enough to give the appearance of continuous illumination when a signal is present. Loss of synchronization can be demonstrated by either disconnecting the

synchronizing link, giving loss of data, or by reducing the time which one of the monostable circuits conducts. The latter case results in incorrect decoding of the incoming data.

Logic circuits.—The circuits shown in Fig. 14 have been used by the author and should prove to be of value to experimenters. The clock pulse frequency is about 1 kc/s, the diodes in the clock generator circuit resulting in a good square wave output. Capacitor C in the monostable circuit has to be adjusted to give the required output pulse width, and a value of about $0.03 \mu\text{F}$ was used by the author. The switching action of the monostable circuit is improved if a diode is used between the collector of Tr1 and the capacitor as in the clock circuit.

IMPROVEMENTS

The frequency-division and time-division multiplexing systems described here are intended for demonstration purposes, but using small improvements they are capable of much better performance. The filter networks in the frequency multiplexing method could be resonant filters or could contain active feedback circuits, allowing many more channels of communication. Step-by-step operations of the time multiplexing system can be demonstrated by the addition of one more wire between the transmitter and decoder, along which the clock signal is sent. The decoder would then contain some form of shift register to provide the scanning signal in much the same way as it is done at the transmitting end.

The author would like to thank his College for permission to publish this paper and Mr. K. Lawton for invaluable assistance in constructing the equipment.

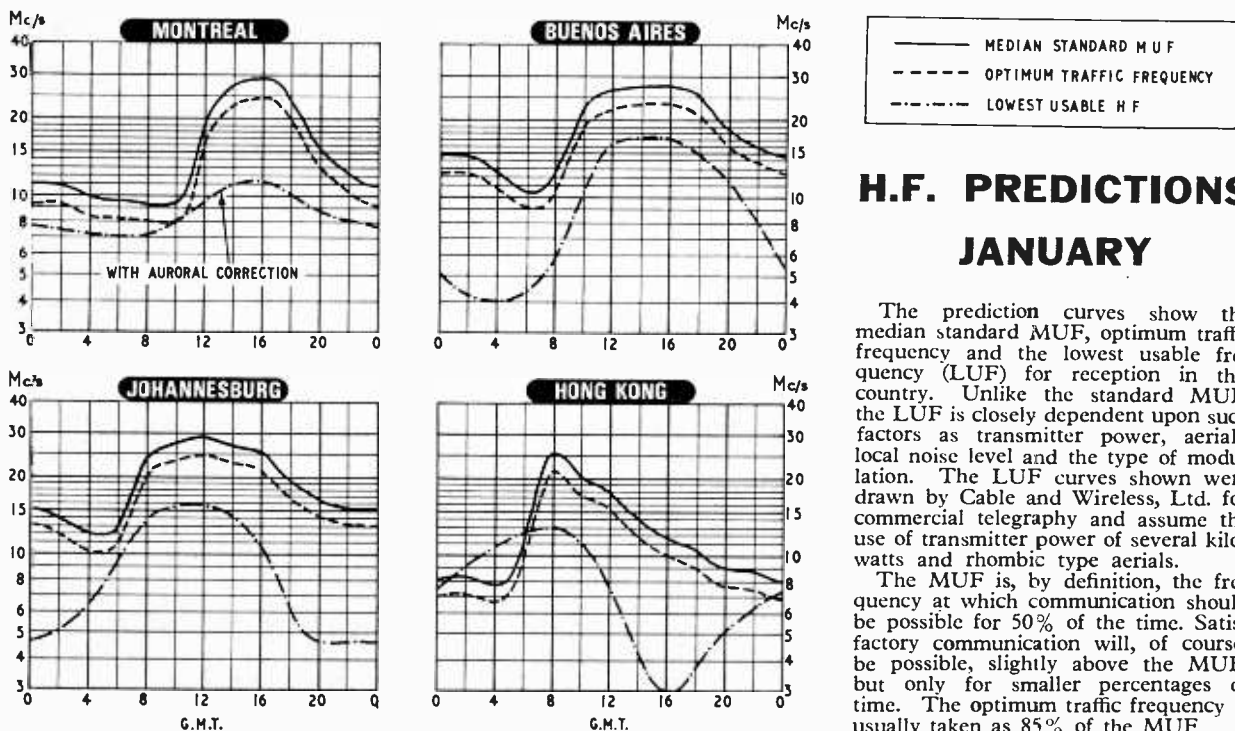

H.F. PREDICTIONS JANUARY

The prediction curves show the median standard MUF, optimum traffic frequency (LUF) for reception in this country. Unlike the standard MUF, the LUF is closely dependent upon such factors as transmitter power, aerials, local noise level and the type of modulation. The LUF curves shown were drawn by Cable and Wireless, Ltd. for commercial telegraphy and assume the use of transmitter power of several kilowatts and rhombic type aerials.

The MUF is, by definition, the frequency at which communication should be possible for 50% of the time. Satisfactory communication will, of course, be possible, slightly above the MUF, but only for smaller percentages of time. The optimum traffic frequency is usually taken as 85% of the MUF.

JANUARY MEETINGS

Tickets are required for some meetings: readers are advised, therefore, to communicate with the society concerned

LONDON

3rd. I.E.E., I.Mech.E. & S.I.T.—“Instrument transducers—a systematic approach” by L. Finkelstein and R. D. Watts at 5.30 at Savoy Pl., W.C.2.

4th. Royal Television Society.—Children’s Lecture on “Thunderbirds” by G. Anderson at 2.0 at I.E.E. Savoy Pl., W.C.2.

4th. I.E.E.—Discussion on “Modular construction in electronic instrumentation” at 5.30 at Savoy Pl., W.C.2.

4th. S.E.R.T.—“Record playing units” by E. W. Mortimer at 7.0 at R.S.A., John Adam St., W.C.2.

5th. I.E.E. & I.Mech.E.—Discussion on “Electrically signalled aircraft flying controls” at 6.0 at 1, Birdcage Walk, S.W.1.

6th. I.E.E. & I.Mech.E.—Colloquium on “Methods of interpreting biological signals” at 2.30 at Savoy Pl., W.C.2.

9th. I.E.E.—Discussion on “Recent developments in fuel cells” at 5.30 at Savoy Pl., W.C.2.

10th. I.E.E.—“Glow and corona discharge tubes” by Dr. F. A. Benson and others at 5.30 at Savoy Pl., W.C.2.

11th. I.E.R.E.—Symposium on “Navigational aids for ground vehicles” at 10.30 a.m. at Middx. Hospital Medical School, W.1.

11th. B.K.S.T.S.—“Audio instruments and measurements” by J. Kuehn at 7.30 at C.O.I., Hercules Rd., S.E.1.

12th. R.T.S.—“Integrated circuits and their applications” by I. Breingan at 7.0 at I.T.A., 70 Brompton Rd., S.W.3.

13th. I.E.E. & I.E.R.E.—Symposium on “Standardization, servicing and maintenance of medical and biological electronic instrumentation” at 10.30 at Savoy Pl., W.C.2.

13th. I.E.E.T.E.—“Semiconductors for power” by K. G. King at 6.0 at I.E.E., Savoy Pl., W.C.2.

16th. I.E.E.—Discussion on “Laboratory work policy” at 5.30 at Savoy Pl., W.C.2.

17th. I.E.R.E.—Symposium on “Radio microphones” at 6.0 at London School of Hygiene and Tropical Medicine, Keppel St., W.C.1.

18th. I.E.E.—“Multi-access computer systems” by Prof. M. V. Wilkes at 5.30 at Savoy Pl., W.C.2.

19th. I.E.R.E. & I.E.E.—“Practical applications of computer programmes in electronic engineering” at 6.0 at I.E.R.E., 9 Bedford Sq., W.C.1.

24th. I.E.E.—“Coding in the auditory nervous system” by Dr. I. C. Whitfield at 5.30 at Savoy Pl., W.C.2.

25th. B.K.S.T.S.—“An audio noise reduction system” by Dr. R. M. Dolby at 7.30 at C.O.I., Hercules Rd., S.E.1.

26th. I.E.E.—“Ion propulsion” by D. Gignoux and J. Lazar at 5.30 at Savoy Pl., W.C.2.

27th. I.E.E.—Discussion on “Use of electric optic effect for light modulation” at 5.30 at Savoy Pl., W.C.2.

27th. R.T.S.—“Education and closed circuit television” by W. G. Beaton at 7.0 at I.T.A., 70 Brompton Rd., S.W.3.

31st. I.E.E., I.Mech.E. & R.Ac.S.—Colloquium on “Adaptive control for aircraft” at 2.30 at Savoy Pl., W.C.2.

31st. I.E.E.—Discussion on “Some recent developments in servo-operated recorders” at 5.30 at Savoy Pl., W.C.2.

BELFAST

10th. I.E.E.—“An introduction to information and communication theory” by Dr. A. M. Rosie at 6.30 at Ashby Institute, Stranmillis Rd., Belfast 9.

BIRMINGHAM

17th. S.E.R.T.—“Post Office Tower, London” by K. J. Lonnon at 7.15 at the University of Aston, Gosta Green.

BRADFORD

31st. I.E.E.—“The entrance requirements for degree courses and final results” by Prof. G. N. Patchett at 6.30 at the University.

BRIGHTON

12th. I.E.E.—“The engineer and the law” by H. B. Morton at 6.30 at the College of Technology, Moulsecomb.

BRISTOL

19th. I.E.R.E., R.Ac.S. & I.E.E.—“Automation in North Atlantic air traffic control” by H. Cherry at 7.0 at the University.

31st. I.E.E.T.E.—“The future of telecommunications” by D. A. Barron at 7.45 in the Large Conference Room, Council House.

CARDIFF

11th. I.E.R.E.—“Silicon controlled rectifiers” by R. G. Dancy at 6.30 at the Welsh College of Advanced Technology.

13th. R.T.S.—“Latest developments in camera tubes” by W. E. Turk at 7.30 at the Angel Hotel.

CHELMSFORD

16th. I.E.E. & I.E.R.E.—“Post Office towers and trunks” by J. H. H. Merriman at 6.30 at the Lion and Lamb Hotel.

CHELTENHAM

20th. I.E.R.E.—“Quality and reliability” by J. G. Alder and D. Newton at 7.0 at North Gloucestershire Technical College.

EDINBURGH

10th. I.E.E.—“A theory and technique of non-linear process identification” by A. B. Gardiner at 6.0 in the Carlton Hotel, North Bridge.

11th. I.E.R.E.—“The use of graphic input/output equipment with computers” by E. J. C. Fowell at 7.0 at Dept. of Natural Philosophy, the University.

17th. I.E.E.—“West London area traffic control experiment” by B. M. Cobbe at 6.15 in the Carlton Hotel, North Bridge.

FARNBOROUGH

12th. I.E.R.E.—“Proximity sensing by magnetic induction” by D. Barnard at 7.0 at the Technical College.

GLASGOW

9th. I.E.E.—“A theory and technique of non-linear process identification” by A. B. Gardiner at 6.0 in Room 24, the University of Strathclyde.

12th. I.E.R.E.—“The use of graphic input/output equipment with computers” by E. J. C. Fowell at 7.0 at Inst. of Engrs. and Shipbuilders, 39 Elmbank Cresc.

26th. I.E.E.—“Displacement capacitance transducer for study of cardiovascular science” by D. N. Smith at 6.0 in Room 24, the University of Strathclyde.

HORNCHURCH

26th. I.E.R.E.—“Some applications of electronics to oceanography” by A. M. East at 6.30 at the College of Further Education, Ardleigh Green Road.

LIVERPOOL

18th. I.E.R.E.—“Modern trends in nuclear electronics and why” by H. Bisby at the College of Technology, Byrom St.

MANCHESTER

10th. I.E.E.—“Post Office towers and trunks” by J. H. H. Merriman at 6.15 in the Renold Building, the University’s Institute of Science and Technology.

NEWCASTLE-UPON-TYNE

11th. I.E.R.E.—“Micro-miniaturized S.S.R. transponder” by D. H. Mehrtens at 6.0 at Inst. of Mining and Mechanical Engrs., Neville Hall, Westgate Rd.

16th. I.E.E.—“Research and development in control engineering” by Prof. J. H. Westcott at 6.30 at Rutherford College of Technology.

18th. S.E.R.T.—“Aerials” by F. J. U. Ritson at 7.15 at the University.

NEWPORT, I.O.W.

11th. I.E.E., I.Mech.E. & R.Ac.S.—“The Council of Engineering Institutions—how does it affect the professional engineer?” at 7.30 at the Red Lion Hotel.

27th. I.E.E.—“Telecommunications in our future society” by Prof. C. Cherry at 6.30 at the Isle of Wight Technical College.

NOTTINGHAM

11th. I.E.R.E.—“The engineering of computer control in the engineering industry” by K. A. MacKenzie and B. Revell at 6.30 at Dept. of Physics, the University.

OXFORD

10th. I.Prod.E.—“Lasers and their application” by Dr. D. Walsh at 7.30 in the Dept. of Engineering Science, the University.

PAISLEY

18th. I.E.E.—“Teaching transistor electronics” by V. H. Attree at 6.0 at the College of Technology.

PLYMOUTH

5th. R.T.S.—“Teaching television” by A. M. Jones at 7.30 at the Studios of Westward Television.

PORTSMOUTH

11th. I.E.E.T.E.—“Lasers and their uses” by Dr. J. M. Burch at 7.30 at the College of Technology, Anglesea Rd.

25th. I.E.R.E.—“Circuit and systems design by digital computer” by J. S. Reynolds at 6.30 at Highbury Technical College, Cosham.

READING

18th. I.E.R.E.—“Self-adaptive control systems” by P. Atkinson at 7.30 at I. J. Thomson Physical Laboratory, the University.

SOUTHAMPTON

10th. I.E.E.—“Electrostatic machines, past, present and future” by Dr. A. W. Bright at 7.0 at the Lancheater Theatre, the University.

17th. I.E.R.E. & I.E.E.—“Colour television” by S. M. Edwardson at 6.30 at Lancheater Theatre, the University.

STAFFORD

17th. I.E.R.E.—“Electronic exchanges” by E. S. Grundy at 7.15 at the College of Further Education, Tenterbanks.

WOLVERHAMPTON

10th. I.E.E.T.E.—“Microelectronics” by G. W. A. Dummer at 7.0 at the College of Technology, Wulfruna St.

NEW PRODUCTS

equipment systems components

CARTRIDGE PLAYER

AN 8-track stereo cartridge system, for which RCA Victor provides the recorded tapes, is being introduced to Europe by Motorola. The basic player mechanism (overall dimensions $3 \times 6.125 \times 6.75$ in with preamplifier) will be supplied by Motorola to British manufacturers for incorporation into car, home or portable reproducers. Using $\frac{1}{4}$ in continuous tape the playing time available would be up to 80 minutes for a 400 ft length and 40 minutes for 200 ft tapes. The tape playing life is said to be 250 hours. Automatic track selection

with manual override selects the required track pair but no particular part of the recording. The player will not stop until the cartridge is withdrawn. Motorola claim that this deck has a tape speed $\pm 2\%$ at room temperature of $3\frac{1}{2}$ i.p.s. with total wow and flutter of 0.25%. Crosstalk is stated to be 45 dB at 1 kc/s and 25 dB at 8 kc/s with 40 dB separation at 1 kc/s and 8 kc/s and 25 dB at 100 c/s. The frequency response is stated to be "flat" from 30 c/s to 10 kc/s.

WW 301 for further details

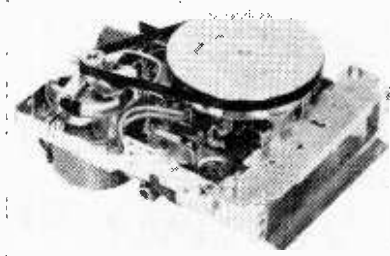

Autobalance Bridge

THE unusually wide range of measurements that can be undertaken by the Wayne Kerr B331 autobalance bridge is indicated by the extreme values in the various units. Using the 1 kc/s internal source and detector, the overall measurement ranges are 0.0001 pF to 0.25 Farad, 1 picomho to 1 kilomho, 1 milliohm to 1 T Ω (10^{12} ohms) and 100 nH to 250 MH (Megahenrys). The full 0.01% accuracy applies from 1 pF to 10 μ F, and from 10 nanomhos to 100 millimhos. Two meters provide simultaneous readings of the in-phase and quadrature terms of any component or complex impedance. Push buttons, associated with illuminated in-line displays, permit both readings to be backed-off by three decades, yielding a 6-figure resolution on all ranges. Special circuits are built-in to compensate automatically for the impedance of the measurement leads, which are terminated in an advanced type of Kelvin

clip. Outputs are provided for operating digital voltmeters, printers, recorders, pass/reject mechanisms or control circuits. Sockets for external standards permit comparative measurements and, used with the vernier controls, a discrimination of 10 parts per million can be realised. Wayne Kerr Ltd., Sycamore Grove, New Malden, Surrey.

WW 302 for further details

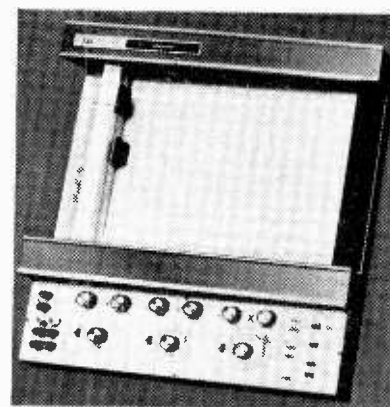
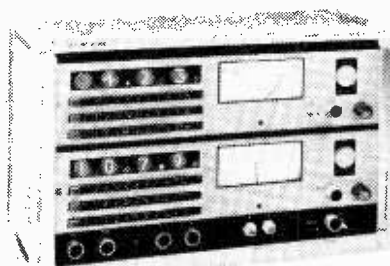

3-INPUT PLOTTER

FROM Electronic Associates Limited, Burgess Hill, Sussex, comes the 1131 Variplotter, designed for applications requiring simultaneous plotting of two variables against a third. Three independent servo-drive systems are provided, which with a basic sensitivity of 1 mV/in, 18 calibrated ranges, and continuously variable scale-factor potentiometers, provide flexibility in operation. A built-in timebase adds a t-y plotting capability, permitting full-scale sweeps over six calibrated ranges from 0.5 s/in. to 20 s/in. Separate timebase and pen-lift controls allow "dry runs" for scaling, prior to recording. Using solid-state circuitry and a zener diode reference system, the 1131 possesses plug-in ink cartridges, back-lighted control switches, plug-in filters for line frequency and noise suppression, and blower type paper hold-down. It has a static accuracy of $\pm 0.1\%$; dynamic accuracy of $\pm 0.2\%$ at 7 in/s; and repeatability of $\pm 0.5\%$. Slewing speed is 17 in/s for the arm and 20 in/s for the pens. Input resistance is 2.5 megohms/V on ranges up to 20 mV/in, and 1 megohm constant on higher ranges.

WW 303 for further details

8+8W Amplifier

INTENDED for use with ceramic cartridges, the Series 3 solid-state stereo amplifier with 8W output per channel is produced by the Tripletone Manufacturing Co. Ltd., 241a, The Broadway, Wimbledon, London, S.W.19. Output impedance is 15 Ω and the distortion is stated to be less than 0.2% at 8W r.m.s. The frequency response is flat ± 1.5 dB from 30 c/s to 20 kc/s. Sensitivities for 8W output are: disc 80mV into 2 M Ω ; tape 80 mV into 100 k Ω ; and radio 200 mV into 100 k Ω . The hum and noise level is -60dB referred to 8W. The price is £29 19s 6d.

WW 304 for further details

REED RELAYS

REED relay type 5858 by Hendrey Relays & Electrical Equipment Ltd. is suitable for ground or airborne use, with limiting values of 5 c.p.s. to 2 kc/s at 10 g and 50 g applied in any direction. The energising coil and reed units are encapsulated in a steel case which provides both mechanical and magnetic protection. The encapsulating material is an epoxy resin having excellent electrical characteristics and good temperature performance. The resin also forms the base of the relay carrying the connection pins, thus forming a robust unit unaffected by humidity, and suitable for use in adverse environmental conditions in ambient temperatures from -60°C to $+120^{\circ}\text{C}$. The reeds are guaranteed to give a minimum of 2×10^6 operations on full load, and response time of the contacts is better than 2 ms, with negligible bounce, both making and breaking. Maximum rating is 0.5 A or 30 V d.c. for 10 W resistive loads. Inductive loads should be suitably quenched. Three standard contact arrangements are provided: (a) two normally open; (b) four normally open; (c) two normally open and two normally closed. Coils can be wound for any d.c. voltage up to 100 V d.c. The relay is available in a range of terminations and mountings.

WW 305 for further details

Stereo Signal Generator

SEVERAL modifications have been made to the f.m.-a.m. signal generator MS27, by Radiometer of Copenhagen, so that it can now accept stereophonic modulation. Used in conjunction with the composite output of a stereo generator such as the Radiometer SMG1 it is possible to test stereo receivers at both i.f. and v.h.f. The modulation frequency response referred to the 1 kc/s level is within ± 0.5 dB from 10 c/s to 60 kc/s.

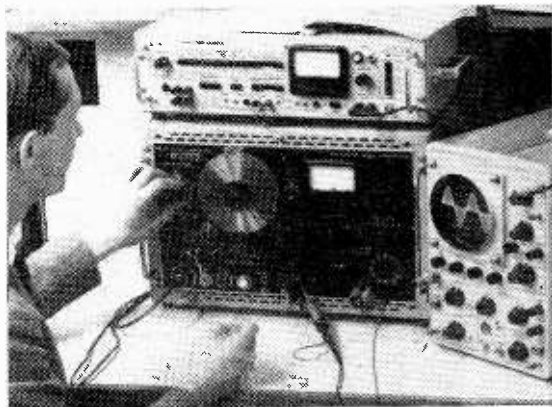

WW 307 for further details

Personal Computer

INTENDED as a teaching aid, the Personal Analogue Computer (P.A.C.) by Pastoriza Electronics Inc. has been designed specifically for use by engineering students. This educational instrument provides students with a model that is somewhere between an actual dynamic physical system and a mathematical representation of that system. By using it, the student gains experience in associating physical behaviour with solutions of differential equations. P.A.C. consists of a control unit, one adder, two coefficient multipliers, two integrators, and an assortment of patch cords.

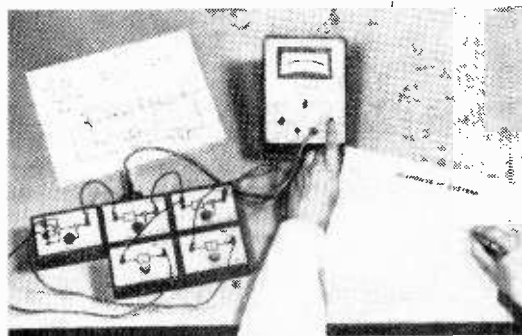

Export distributor of the computer is the Raytheon Company, International Sales and Services, Lexington, Massachusetts, U.S.A.

WW 306 for further details

WARNING NOTE GENERATOR

BLEEPTONE is the onomatopoeic name of a compact, lightweight sonic generator. With a diameter of $1\frac{1}{8}$ in, and weight of only $1\frac{1}{2}$ oz, this device is intended for use as an audible note generator for warning purposes in commercial vehicles, stationary engines, boats, and for blind persons at pedestrian

crossings. It can be employed in places with heavy background noise and its effect will not be masked. It could be applied to sound a warning in a vehicle driver's cab, when tyre, oil, or brake pressures pass beyond a permitted level. The makers state that the note can be heard at distances up to 500 ft. The frequency at 12 V is 2.5 kc/s, at 16 V it is 2.6 kc/s, and at 2 V it is 2.2 kc/s; these d.c. voltages are nominal, maximum, and minimum, respectively. The current drain is 12-15 mA at 12 V, and a maximum of 20 mA at 16 V. Distortion is not more than 10% total harmonic content at nominal voltage. The drive circuit is similar to that used for self-maintained tuning forks. Two separate coils are arranged in the magnetic circuit, one to drive the rocking armature in the earpiece and the other to pick up the induced signal and provide feedback to the base of a transistor, which, with associated components forms an amplifier circuit. The fundamental frequency of operation is determined basically by the mechanical characteristics of the rocking armature. A. P. Besson and Partner Ltd., St. Joseph's Close, Hove, Sussex.

WW 308 for further details



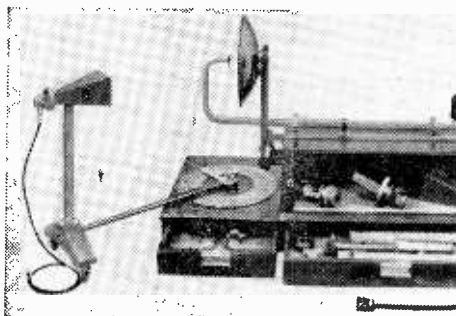

EDUCATIONAL AERIAL TEST BENCH

THE Sanders division of Marconi Instruments Ltd., Gunnels Wood Road, Stevenage, Herts., have introduced an aerial test bench. Designated type 6452, the bench enables the polar diagram and gain characteristics of a range of aerials supplied with the bench to be measured as instructional exercises. The aerial types supplied with the 6452 are wave-guide horns, dipole feed, horn feed, paraboloid, dielectric end-fire, narrow wall and broad wall shunt slot linear arrays. Polar diagrams are measured by using the aerial on test to transmit and the horn (shown in the photograph) to receive. The resulting signal is then monitored on a v.s.w.r. indicator and noted for that particular position and angular deflection. Most of the aerials are designed to operate at a frequency of 9 Gc/s.

WW 309 for further details

Transistorized Multimeter

THE transistorized multimeter type 1305 by Comark, Littlehampton, Sussex, has input impedances of $1\text{ M}\Omega$ 30 pF and $2.2\text{ M}\Omega$ 20 pF for the voltage ranges 1 mV to 300 mV and 1 V to 1 kV respectively. The minimum bandwidth 5 c/s-500 kc/s (-3 dB level) is for the a.c. $\times 10$ range and 5 c/s-1 Mc/s (-3 dB level) for the a.c. range. There are facilities to drive a recorder at 200 μA and 440 mV. Accuracies for d.c., a.c. and a.c. $\times 10$ are respectively 2%, 3%, 4% with 0.1% per $^{\circ}\text{C}$ temperature variation. The a.c. scale is calibrated in r.m.s. for sine wave only. Two scales for resistance measurements provide linear ranges of from $100\ \Omega$ f.s.d. up to $1\text{ M}\Omega$ f.s.d. and the usual reciprocal maximum readings of 10 k Ω and 100 M Ω . The size of the multimeter is 6.25 \times 5 \times 3.5 in and it weighs 2.5 lb. It is powered by three RM-12R mercury cells having a total life of 1,000 hours.

WW 310 for further details

Digital Readout Device

A DIGITAL readout device, the TNR-50, by Transistor Electronics, U.S.A., is available in eight models to handle 8-wire b.c.d. input in 8-4-2-1 code with inputs as small as 3.5V. Other input codes can be accommodated. A supply voltage of +180V d.c. $\pm 10\text{V}$ d.c. at 2 to 12 mA is required. Elements of the rectangular neon readout tube are controlled by internal all-transistor, decoder-driven circuitry that eliminates diode decoders, reducing the number of semiconductor components by 60%. All tube elements may be turned off when no indication is required. The readout utilizes a rectangular, long life Nixie tube with a flat face which brings numerals closer to the front for wide-angle viewing. Numerals are 0-610 in high. Life expectancy is stated to be 100,000 to 200,000 hours. The unit measures $1\frac{1}{4}$ in high by 1 in wide. Its overall length ranges from $3\frac{1}{8}$ in to $4\frac{3}{8}$ in depending upon model and ter-

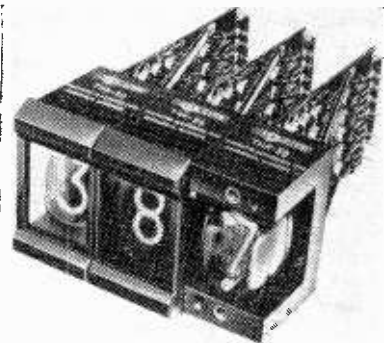

minimal type selected. A choice of turret lug terminals or edge connectors is offered. This TNR-50 series may be custom designed to meet special electrical functions such as coded input to octal readout, counters and memories. Litton Precision Products, 503, Uxbridge Road, Hayes, Middlesex.

WW 311 for further details

10 ns Current Driver for Store Testing

DUAL current pulses identical in rise time, fall time, pulse delay and pulse width can be delivered by the model 1720 current driver developed by Computer Test Corporation, 3, Computer Drive, Cherry Hill, N.J., U.S.A. In tests on coincident-current stores, the 1720 can serve effectively as two individual drivers. Output A can drive an X-axis line while output B drives a Y-axis line. Since the current pulse parameters of both outputs are adjusted coincidentally by a single set of controls, the dual output design reduces the test set-up time. Current amplitudes of the output pulses can be adjusted independently of one another over a continuous range of 50 mA to 600 mA. The full rated 1 A output of the driver can be achieved by throwing a front panel switch which commons the two outputs internally. The 1720 is also a true bi-polar current driver, providing positive or negative pulses relative to ground by operation of a polarity switch.

The output voltage rating is 60 V, positive or negative, and the driver is capable of withstanding a back e.m.f. of the same magnitude without damage. The 60 V output and the low output capacitance of 40 pF (worst case) combine to equip the driver with the ability to drive large inductive loads. The output current pulse has fast, linear rise and fall slopes, with durations less than 10 ns. Rise and fall times can be adjusted independently of each other.

Pulse-shape is square-cornered, without overshoot, ringing or droop. Pulse-width is variable from 10 ns and pulse delay from 0 to 10 μs . The instrument is both short-circuit stable and open-circuit stable. Automatic current limiting is provided to a maximum average of 200 mA. When this average current is exceeded, trigger pulses to the driver are automatically disconnected within 5 μs . Accordingly, any duty cycle up to approximately 95% can be achieved with the driver.

WW 312 for further details

Wire Stripper

FOR stripping p.t.f.e. insulation from wire, sizes 7/0-0048, 7/0-0076, 19/0-0076 and 19/0-006, Hellermann have designed the H63 compression wire stripper. It is stated that this tool will strip off insulation without nicking or scratching the wire. Hellermann Electric Ltd., Gatwick Road, Crawley, Sussex.

WW 313 for further details

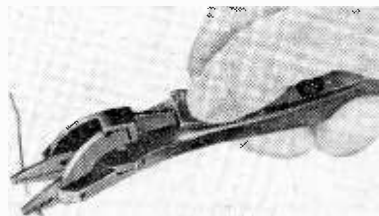

MINIATURE CERAMIC CAPACITORS

THE C333 series of miniature ceramic capacitors by Mullard are rectangular in shape and are only 1.9mm thick to allow high packing densities on printed circuit boards using a 0.1 in grid. The capacitors are suitable for use in both domestic and industrial equipment. They consist of a thin plate of metalized ceramic material which is insulated with a protective lacquer to assure satisfactory performance under humid conditions. Each capacitor in this series measures $5 \times 8.5 \times 1.9$ mm (excluding leads of 13.5 mm). The capacitance range is 3.9 pF to 150 pF, with a tolerance of 0.5 pF or $\pm 2\%$, whichever is the greater. Working voltage is 40 V d.c. over a temperature range of -25°C to $+85^\circ\text{C}$ and the insulation resistance measured at 10 V is greater than 1,000 M Ω . The close tolerance and high

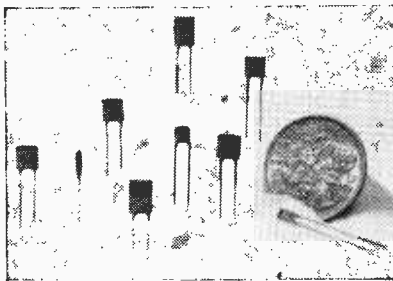

stability of the new capacitors is said to make them particularly suitable for use in television i.f. transformers, tuned circuits and other applications calling for low-loss and high performance. Mullard Ltd., Mullard House, Torrington Place, London, W.C.1.

WW 314 for further details

Sweep Generator

THE Grundig (valve) WS3 sweep frequency generator, used in conjunction with an oscilloscope, displays all filter and pass-band response curves over a wide frequency range. Centre frequency ranges are 4 to 230 Mc/s and 470 to 800 Mc/s. The high output level of 500 mV at 60 Ω impedance is suitable for work on amplifiers, one stage at a time. The instrument is also suitable for trimming adjustments on aerials, for investigating cables and for transmission measurements of tank circuits, tank circuit filters, resonant circuits and bandpass filters. The unit comprises a wobulator, a self-contained marker oscillator and a quartz crystal calibrator. In the u.h.f. range, the output frequency is generated by means of an oscillator with a continuously adjustable centre frequency. In the range 4 to 230 Mc/s, a fixed oscillator and a variable oscillator work via a mixer that supplies the filtered difference frequency simultaneously to the sockets for direct and adjustable outputs. The adjustable marker generator has its own scale and the purpose of the additional fixed frequency crystal oscillator is to supply a marker pip spectrum with spacing of 2 Mc/s, 5 Mc/s or 10 Mc/s selected by a switch; an off position is included. It is possible to plug in separate crystals having a fundamental frequency within the range 2 to 11 Mc/s in order to produce markers with special spacings. The determination of bandwidth is independent of the position of the centre frequency. This is particularly important in the case of u.h.f., where exact

plotting of filter curves is possible by manipulating the fixed markers. The response at and between the picture and sound carriers in television i.f. stages can be accurately determined (irrespective of any sideband reversal) by plugging in a suitable reference crystal as described. Calibration of the adjustable marker-generator can be made with crystal accuracy. Reading errors are minimized by positive indication of the range in use on both the wobulator (sweep frequency generator) scale and on the marker-generator scale. Grundig (Great Britain) Ltd., Newlands Park, Sydenham, London, S.E.26.

WW 315 for further details

V.H.F. TRANSCEIVERS

TWO new compact multi-channel v.h.f. low-power transceivers are being produced by G.E.C. They are designed for use as base stations in communications networks utilizing pocket radiotelephones such as the "Courier" and "Lancon." Both f.m. and a.m. versions are available, and each type consists of two items—a transistor transmitter/re-

Solenoids

A SERIES of general-purpose solenoids has been developed by the Electro-Mechanical Division of Standard Telephones and Cables, Ltd., Components Group, Footscray, Sidcup, Kent. The smallest unit (size 1) is only 0.5 in³ volume, weighs 1½ oz, and is said to have a performance comparable with that of conventional units 60% larger. Operating under 10% working-cycle conditions, the d.c. version can provide a force of 11 oz over a stroke of $\frac{3}{32}$ in for an input power of 30 W. The d.c. version of the next largest unit in this series (size 2) is 0.8 in³ volume, weighs 2¼ oz and, under the same operating conditions, including a $\frac{7}{32}$ in stroke, produces a force of 25 oz for 35 W input. Both units are being life tested and have completed over one million operations under $\frac{7}{32}$ in stroke—10% working-cycle conditions. The new units are available in a.c. or d.c. versions with coils from 6 V to 48 V rated from 5% working-cycle to continuous operation, and are supplied with push or pull plungers. The plungers for pull use have either clevis or tapped-hole coupling facilities; push plungers have a non-magnetic thrust rod.

WW 316 for further details

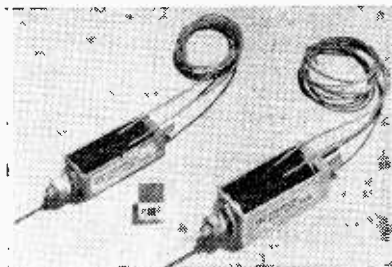

ceiver measuring approximately $4\frac{1}{2} \times 10 \times 12\frac{1}{4}$ in, and a telephone-type control unit for local or extended control up to a distance of 100ft. Frequency range of the equipment is 70-100 c/s and 156-174 Mc/s for the f.m. model, and 62-88 Mc/s, 79-101 Mc/s and 156-174 Mc/s for the a.m. version. Other ranges can be supplied. The equip-

ment is designed for 25 kc/s channel spacing. G.E.C. (Electronics) Ltd., East Lane, Wembley, Middlesex. WW 317 for further details



CO-AXIAL TERMINATIONS

THE Trio 600 series 2 W and 5 W terminations are low reflection loads for terminating 50 Ω coaxial devices in their characteristic impedance. The frequency range is d.c. to 2.5 Gc/s with the v.s.w.r. of the termination less than 1.03. Maximum average sine wave power rating for the Type 600-2 is 2 W, for the 600-5 it is 5 W. The maximum peak power, with 1 μ s pulse length, is 250 W for the 600-2 and 500 W for the 600-5. Termination accuracy is 50 $\Omega \pm 1\%$ at d.c. Applications include acting as a matched termination for v.s.w.r. measurements of coaxial components; impedance termination for coaxial devices such as directional couplers and filters; as a dummy load for small transmitters up to 5 W output; and as a reference load for a hybrid junction or a power divider. Trio Instruments Ltd., Burnham Road Trading Estate, Burnham Road, Dartford, Kent.

WW 318 for further details

SUB-MINIATURE MICRO SWITCHES

SUBMINIATURE snap action micro switches from Cemco, U.S.A. are marketed in this country by A. F. Bulgin & Co. Ltd., By-Pass Road, Barking, Essex. The MAC 100-500 series operate at approximately 30gm, with small movements, and have a mechanical life of over 1 million operations. Housed in compression moulded phenolic cases, they operate within the temperature range -65°F to $+350^{\circ}\text{F}$. Electro-plated integral contact tags are easy to solder, and the contacts are silver. These switches meet MIL 6743 requirements, and are approved at up to 250V resistive. This is derateable for capacitive/inductive loads and for longer life. Types within the range are end-button with low force switch; end-button with wire operator fitted; end-button with leaf operator fitted, middle button with wire operator fitted, and middle button with leaf operator fitted.

WW 319 for further details

RADIO MICROPHONE

RADIO microphones and equipment by S.N.S. Communications Ltd., Tropical Works, 851 Ringwood Road, West Howe, Bournemouth, Hants. now include the Type C Mk 11 system. This system, using phase modulation, permits five radio microphones to be operated simultaneously in the same location without mutual interference. In the transmitter, two stages of audio amplification modulate an overtone crystal oscillator circuit, the output of which is multiplied by a two-stage r.f. amplifier. The d.c. voltages for the oscillator and audio stages are stabilized at 7.5 V to ensure absolute minimum drift right to the end of battery life. The transmitter frequency range is 174.6 to 175 Mc/s in any one

of five channels. Frequency stability is 0.003% from -10°C to $+35^{\circ}\text{C}$. Power output is 12 mW maximum. Audio frequency response is flat $\pm 2\text{dB}$ from 30 c/s to 8 kc/s. The power supply required is a 9 V battery, PP4 or equivalent.

The receiver has a squelch unit built in to quieten the system when the transmitter is switched off. This is particularly useful in small installations where the user wishes to control the system from the microphone end. A range of up to 50 yds is stated to be possible indoors, and greater distances outdoors. The receiver's bandwidth is ± 20 kc/s and its a.f. response is similar to that of the transmitter. The output can be

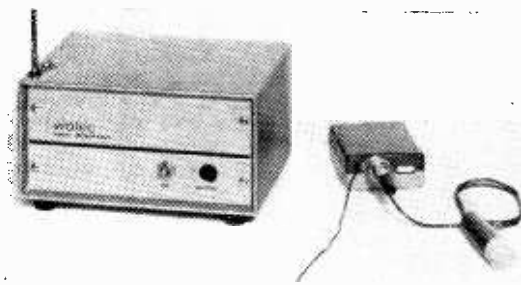

100 to 150 mV into 100 k Ω , or -50 dBm for 30 Ω balanced. The weight of the transmitter is 8 oz including battery, and the weight of the receiver including battery and aerial is 9 lb. Type C equipment is G.P.O. approved and meets specs W6489 and W6490.

WW 320 for further details

Dual-purpose Transistor

SEVERAL new semiconductor devices are available from SGS-Fairchild Ltd., Planar House, Walton Street, Aylesbury, Bucks. Among them is the 2V435, a dual p-n-p diffused silicon planar epitaxial device. Intended as a medium current switch and v.h.f. amplifier, it is also useful for digital and analogue applications up to 300 mA. A high gain bandwidth product, and high ft at high currents make it a good unit for core store applications. It is also suitable for industrial chopper circuits. There is also a silicon diode for use as a series element in regulated

power supplies. Known as the BD118, it is encapsulated in a TO-3 can, and has a power dissipation of 15W. The V_{CEO} is 60V, and the gain characteristic is said to be virtually linear over a range of current from 100 mA to 2A. A package of 7 matched transistors and 1 diode for 30W hi-fi amplifiers is known as the AF12. An accompanying data sheet includes a recommended amplifier circuit with a guaranteed performance. Full output is 30W into an 8 Ω load, and 16W into a 15 Ω load, maintained over the audio range.

WW 321 for further details

Multipole Plug Socket

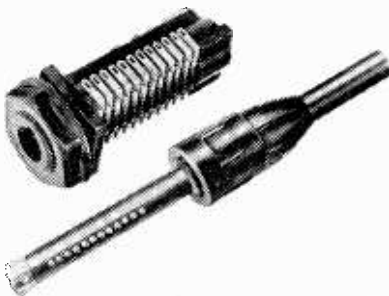

A QUICK and secure method of connecting miniature cables with up to 12 cores is said to be provided by the Rendar multipole jack plug and socket. In addition to its form as a connector, it can also be supplied with a large number of combinations of make and/or break contacts on the socket. Electrical contact is made by a slight clockwise turn of the plug after insertion, the plug remaining locked in this position. Rendar Instruments Ltd.

WW 322 for further details

Spectrum Analyser

THE Tektronix Type 491 is a precision, wide band spectrum analyser designed for rugged environmental conditions and easy mobility. A rack mounted version, the Type R491, is also available which is electrically identical and occupies a rack height of only 7 inches. Resolution and calibrated display dispersion controls are coupled, providing narrow resolution bandwidth at narrow dispersion, and wide resolution bandwidth at wide dispersion. Since dispersion is calibrated, frequency differences can be read directly from the c.r.t. Internal phase

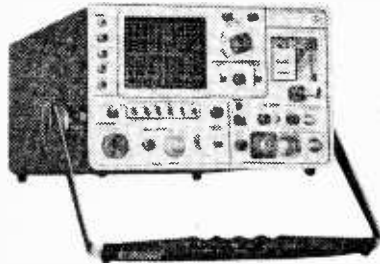

lock provides stable displays even at 1 kc/s per div. dispersion. Other features of the 491 are minimum c.w. sensitivities from -110 to -70 dBm depending upon frequency, display flatness of ± 1.5 dBm over 100 Mc/s dispersion, trace intensification of high-speed segments of the displayed waveform, long persistence (P7) phosphor, and d.c. coupled recorder output. The oscilloscope-type triggering and sweep circuitry enables triggering from internal, external or line sources, with sweep speeds from $10 \mu\text{sec/div.}$ to 0.5 sec/div. The carrying handle adjusts for various tilt positions and serves as a support handle. A front panel cover acts as a storage case for all the standard accessories including adapters, cables, waveguide mixers and coaxial attenuators. The cabinet model is $7\frac{1}{8}$ in high, $12\frac{3}{8}$ in wide (including handle), $20\frac{1}{2}$ in deep (including rear feet and front cover). It weighs 40 lb with all accessories. Power requirements are 50 watts, at 90 to 272 volts a.c., 48 to 440 c/s.

WW 323 for further details

Stretch Cable

A NEW "stretch" cable has been announced by Bush Beach & Segner Bayley. Known as the Retraflex range, these cables readily stretch but repeatedly return to the original length without tangling. Retraflex cables are suitable for rack or drawer mounted electronic instruments, shielded microphone cords, cords for headset microphone assemblies, communication and electronic control cable, portable lighting equipment, soldering irons, household appliances and for any application where extensibility is required without the use of coils or excessive weight. The cable is available in continuous lengths on spools or cut lengths with the required terminals. Cables with one or multiple conductors use an elastomeric core and permit repeated stretching of up to 200% (from 100 to 300 ft, for example). Special constructions are available to order.

Three different types of jackets are manufactured for the cables—high strength silicone rubber, specially compounded polyvinyl chloride plastic or co-polymers of butadiene and styrene rubber. The silicone rubber jackets have moisture resistance, low temperature flexibility, and resistance to ozone, radiation, fungus and corona. They are chemically inert and provide protection in corrosive atmospheres. The plastic

compound jackets are oil resistant and have low temperature characteristics. The styrene rubber jackets offer high resilience, good abrasion resistance, low water absorption and good electrical properties. Within the whole range of these three types of jackets, Bush Beach & Segner Bayley, of Marlow House, Lloyds Avenue, London, E.C.3, are able to supply various conductors, bare and tinned copper, cadmium copper, special alloys, etc., and colour codings are available.

WW 324 for further details

Soldering Kit

THE Antex precision soldering kit consists of a durable and rigid plastic "tool-box" with a lift-off cover that can also serve as an iron stand. Contained in the box is an Antex Model CN 240 15 watt precision miniature soldering iron, fitted with a $\frac{3}{8}$ in nickel plated bit. Two spare interchangeable bits ($\frac{3}{32}$ in and $\frac{3}{16}$ in) are provided to enable a wide variety of work to be undertaken, with a reel of resin-cored solder, a cleaning pad, and a handy heat sink for soldering transistors, etc. In the kit is a 36-page illustrated booklet on "How to solder." All components of the kit fit neatly into place, with room for the iron to be

SUB-MINIATURE TRIMMER

A SUB-MINIATURE wire-wound trimmer potentiometer has been added to the range of resistive components manufactured by Pandect. Its physical outline corresponds to that of a standard TO-5 transistor, and the component is intended primarily for use in aeronautical, military and other high-grade electronic equipment meeting rigorous specifications. The new potentiometer is available in resistance values of 5Ω to $15 \text{ k}\Omega$. It offers the high power rating of 1 W at $+75^\circ\text{C}$. Resistance-welding of base to lid ensures 100% environmental proofing over an ambient temperature range of -70 to $+150^\circ\text{C}$. Adjustment of the potentiometer is made by a slotted spindle. The mechanism incorporates a simple slipping-clutch to guard against accidental damage due to excessive force being applied at the extremes of wiper movement. This arrangement is considered to be superior to internal mechanical stops, which are inevitably small and likely to break off under load. A silicone-rubber "O" ring is fitted to maintain the sealing between the case and spindle. Micro-welded connections are used internally to obtain maximum strength under severe vibration. The lead-out wires, which are gold-plated, arc brought out through a glass-to-metal seal.

WW 325 for further details

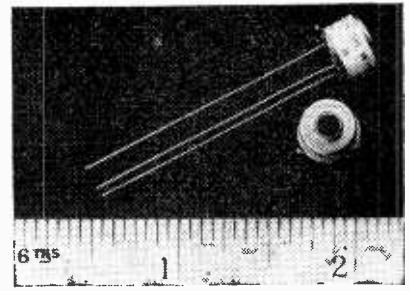

stored complete with mains plug. Price of the kit is £2 9s 6d. Antex Ltd., Grosvenor House, Croydon, Surrey.

WW 326 for further details

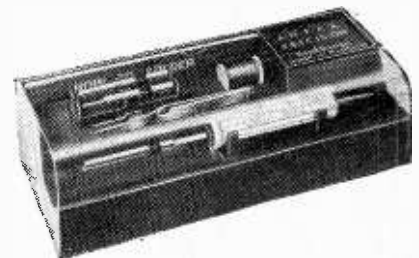

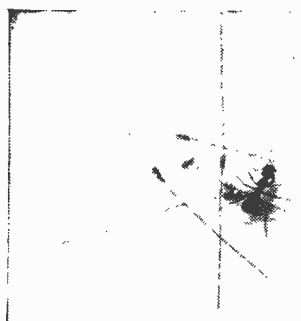

Miniature Resistors

MADE in W. Germany by L. Siegert, Type RKL 2 carbon film resistors are stated to be among the smallest in the world (see ant in photo) with a body length of 0.102 in, a diameter of 0.035 in, and a weight of 0.011 grams. A carbon deposit, applied by pyrolysis to the ceramic substrate, is extended to coat cavities at the ends of the rod. The leads are soldered to nickel plating overlying the carbon film in these cavities, and the leads (copper-nickel alloy) are gold plated to facilitate rapid soldering. Solder with a melting point not greater than 180° C should be used. This series of resistors is colour banded to the international colour code. The range is from 47 Ω to 100 kΩ with tolerances of ±10 % and ±20 %. They have a power rating of 30 mW at 65° C, and a maximum self capacitance of 0.2 pF. Temperature coefficient under 10 kΩ is 250 p.p.m./°C, and from 10 kΩ to 100 kΩ it is 400 p.p.m./°C. Working voltage is 50 V a.c. They have a noise factor of 2 μV/V. In regular production and available through Nutec Electronics Ltd., Mercantor House, 5 East Street, Shoreham-by-Sea, Sussex.

WW 327 for further details

INFORMATION SERVICE FOR PROFESSIONAL READERS

To expedite requests for further information on products appearing in the editorial and advertisement pages of *Wireless World* each month, a sheet of reader service cards is included in this issue. The cards will be found between advertisement pages 16 and 19.

We invite professional readers to make use of these cards for all inquiries dealing with specific products. Many editorial items and all advertisements are coded with a number, prefixed by WW, and it is then necessary only to enter the numbers on the card.

Postage is free in the U.K. but cards must be stamped if posted overseas. This service will enable professional readers to obtain the additional information they require quickly and easily.



THE HOUSE OF BULGIN AT YOUR SERVICE

NEW RANGE OF DURALUMIN KNOBS

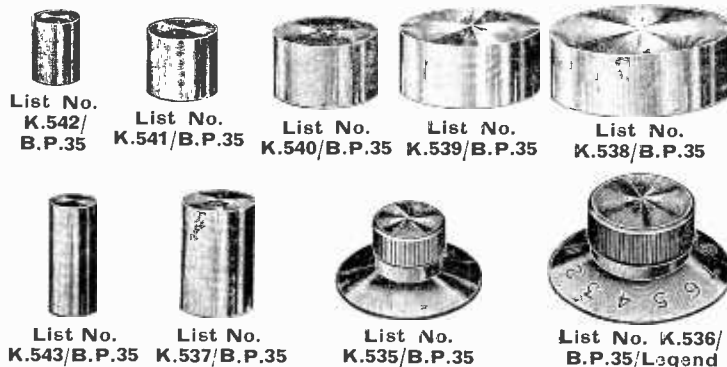

List No.
K.542/
B.P.35

List No.
K.541/B.P.35

List No.
K.540/B.P.35

List No.
K.539/B.P.35

List No.
K.538/B.P.35

List No.
K.543/B.P.35

List No.
K.537/B.P.35

List No.
K.535/B.P.35

List No. K.536/
B.P.35/Legend

A fine new range of Knobs all turned from solid Duralumin and fitted with Allen set screws as standard. Two styles are available, seven plain circular types with spin finished tops and smooth sides; or two skirted types with "spin" tops and ribbed sides. The latter normally have plain skirts but legending is possible to customers' orders.

For full details send for priced data sheet.

NEW RANGE OF 'MULTI-DESIGN' KNOBS

NO GRUB SCREWS
COMPLETELY CONCEALED COLLET FIXING



List No.
K.544/1

List No.
K.545/1

List No. K.546/1

List No. K.547/1



A unique new range of four beautifully designed Knobs produced to the most exacting standards, and varying from 1 in. to 2 1/4 in. The bodies are moulded from black phenolic material, have smooth polished sides and are topped with a "spin" finished decor cap. Fixing is to 1/4 in. shafts by our well proven four-jaw collet which is completely concealed within the Knob moulding itself (and not hidden by the usual bung). For details of this unique range send for data sheet. Full range of Skirted models (see left) soon available.

A. F. BULGIN & CO. LTD.
Bye Pass Rd., Barking, Essex.
Tel: RIPpleway 5588 (12 lines)

MANUFACTURERS AND SUPPLIERS OF RADIO AND ELECTRONIC COMPONENTS TO

| | | |
|--------------|-------------------------|--------|
| ADMIRALTY | MINISTRY OF WORKS | S.B.C. |
| WAR OFFICE | MINISTRY OF AVIATION | G.P.O. |
| AIR MINISTRY | MINISTRY OF SUPPLY | I.T.A. |
| HOME OFFICE | RESEARCH ESTABLISHMENTS | M.P.L. |
| CROWN AGENTS | U.K.A.S.A. | D.S.R. |

WW-104 FOR FURTHER DETAILS

"But where's the asterisked horse?"

LIKE the page in the Wenceslas carol I have been treading somewhat apprehensively in the footprints of the mighty (see the Editorial, November issue) and doing my home work on the Electronics Economic Development Committee's Report, "Electronics and the Future." You no doubt have done likewise, but if not, then I commend this document to your attention, that is if your taste in literature runs to the macabre.

This Domesday Book is in the finest traditions of our industry, which, if it has no other claims to fame, is truly remarkable in that it harbours more committees than it does personnel. This pre-occupation with conclaves, which is accompanied by a secondary phenomenon known as "self-oscillation using paperwork coupling" is something which only a psychiatrist could adequately explain. The equivalent circuit of its first stage is that of a generator operating into a mismatched load impedance, across the terminals of which somebody has carelessly laid a crowbar. The net effect is, of course, that of a display of energy but little or no useful work done.

Now, nearly sixty names are given as having been in committee on this Report and most of them are top people, with, presumably, commensurate salaries. Behind the scenes, unhonoured and unsung, one darkly suspects the presence of a large number of secretaries and officials who actually did the digging out of the data provided. This formidable tally of expensive man-hours sat for two years and then laid its egg in the form of 35 pages of findings and statistics. One statistic which, regrettably, is not given is how much the two-year stint cost.

Statistics galore

Mind you, in other directions there are figures and tables in abundance; a goodly proportion of them carrying footnotes to the effect that they are conjectural or otherwise unreliable. Nevertheless, to the Managing Director who has had the Official Receiver hammering at his door for the past six months, the assurance that £9,916,000 worth of turntable units was made in 1958 must come as a complete answer to all his worries. (It will at least serve as a useful piece of chit-chat to work off on the Labour Exchange clerk when he signs on.)

But it would have been rather nice if, among the heavy-weight stuff we could have been given some trivia; like the net profit made by the industry last year expressed as a percentage of the capital invested. Or the ratio of directly productive employees to the others, or a graph showing the relative growth rates of the two categories over the past 30 years. I should also have liked to know just why the Electronic Engineering Association has been so cagey about giving a figure of employment for the capital goods side and why it only *believes* that output per head is £3,000. Can it possibly be that the E.E.A.'s finger is elsewhere than on the pulse? Or is there a more sinister reason?

I don't know what Her Majesty's Government is making of this Report, but the very best of British luck to you, Mr. Prime Minister, sir.

The most apt comment I can make on it is to quote these lines by Roy Campbell:—

You praise the firm restraint with which they write—
I'm with you there, of course
They use the snaffle and the bit all right
But where's the bloody horse?

For incredibly, but perhaps not altogether unaccountably, the horse, in the shape of criticism of the industry's internal structure and policies, is conspicuous by its absence. Indeed, Dobbin is patted on its invisible rump—"We believe that the industry is therefore soundly based . . ." The leaks in the stable roof and the parlous state of the tack are shrugged off, although it is true that the Government stable-boy comes in for some well-deserved clips on the ear for various sins of omission, including neglect to supply the necessary fodder.

"Thinking is a prelude to production, not a substitute for it." I forget who said that (I'm sure the next post will remind me) but without doubt ours is the thinkingest industry that ever was. Consider, for a moment, two of the five conclusions reached in the Report concerning the consumer goods section of the industry:—

(1) Output is static and exports are low in all but a few fields.

(2) TV and radio receivers manufactured to British standards are not easily exportable to other markets without modifications.

Now, while you are recovering from the explosive impact of these revelations (including the clear implication in (2) that television isn't radio communication), pause and consider that it has taken two years' solid, constructive, co-ordinated thinking by a committee of 60+x to work that lot out. (What's that from the back of the class? Mr. Harold Wilson could have discovered this by spending ten minutes and two bicarb. tablets in any Works canteen at the mid-day break? Black mark that lad!)

Business acumen ?

But the punch line comes in the recommendations which follow. "We have no specific recommendations for [the consumer] industry" says the Report, "since in this field, more than any other, success, both in profit and export performance, depends mainly on business acumen . . ." Since the figures for 1965 show that we exported only 4% of our television sets and 3% of our sound radio receivers, the aforementioned business acumen would appear to have trickled down a crack in the Works floor. But there is still no recommendation; not even the elementary one of designing a set which foreigners would consider to be good value for money.

One would have thought, too, that a warning bell would have been rung about the impact of microcircuits; so it is, up to a point, but the Report says no more (in fact, less) than was being said in *Wireless World* 18 months ago. And events have moved fast since then. Furthermore . . . but I've run out of space.

Now, the suggestion is not that the committee has loafed its way through two years. On the contrary, they have probably all worked extremely hard; which brings us back to the equivalent circuit and the expenditure of a vast amount of energy without doing anything significantly useful. When are we going to exorcise the "Crowbar Effect"?



NEW HIGH EFFICIENCY TOOLS



TEMPERATURES AVAILABLE

- 250°C 27 WATTS
- 360°C 50 WATTS
- 410°C 60 WATTS
- 500°C 95 WATTS

ILLUSTRATED

R 900, RIGHT ANGLE, FITTED WITH STANDARD $\frac{1}{2}$ in. BIT.

For full information and sales apply direct to

HEAD OFFICE SALES & SERVICE

ADCOLA PRODUCTS LTD
ADCOLA HOUSE, GAUDEN ROAD,
LONDON, S.W.4.

Telephones: Macaulay 0291/3 Telegrams. SOLJOINT, LONDON, S.W.4

AUSTRALIAN ASSOCIATES: ADCOLA PRODUCTS PTY LTD., 673 WHITEHORSE ROAD, MONT ALBERT, MELBOURNE
AGENTS IN ALL LEADING COUNTRIES



THE QUEEN'S AWARD
TO INDUSTRY 1966

ERSIN

Multicore

5 CORE

SOLDER

solder dispensers

Hundreds of tons of Ersin Multicore Solder are used annually in the manufacture of electronic equipment. The same high quality solder is available in convenient packages for workshops and service organisations. Here is a selection from the wide range of specifications available. All, except Sizes 11 and 14, contain Ersin Multicore Solder with 5 cores of extra fast non-corrosive flux. The solder wire is ingeniously coiled in the new, handy dispensers enabling the soldering operation to be made simpler.



SIZE 5

SIZE 4A

SIZE 15

SIZE 14

SIZE 5 Contains 12 ft. of 18 s.w.g. Savbit alloy which makes copper soldering iron bits last ten times longer. **2/6** retail.

SIZE 4A A similar dispenser to size 5, but containing 9 ft. of 18 s.w.g. 60/40 alloy. **2/6** retail.

SIZE 15 21 ft. of 60/40 alloy 22 s.w.g. contained in a narrow dispenser for soldering small components, transistors, diodes and printed circuits. **3/-** retail.

SIZE 14 Contains 7 ft. coil of 40/60 alloy 16 s.w.g. Arax acid cored solder for metal repairs. The flux residue may be washed off with water. This solder is not suitable for electrical joints. **3/6** retail.



SIZE 12

SIZE 10

SIZE 11

SIZE 12 102 ft. of 18 s.w.g. Savbit alloy. **15/-** retail.

SIZE 10 212 ft. of 22 s.w.g. 60/40 alloy. **15/-** retail.

SIZE 11 50 ft. of 16 s.w.g. Arax acid cored solder alloy. **15/-** retail.

Bib
REGD
MODEL 8

WIRE STRIPPER AND CUTTER

FOR QUICK AND ACCURATE
FLEX AND CABLE STRIPPING
WITHOUT NICKING WIRE

Cuts wire cleanly and splits plastic twin flex. Immediately adjustable to eight sizes of flex or cable by ingenious gauge selector. Essential for factory maintenance service, and home use. Fitted with plastic cushioned handles, nickel plated.

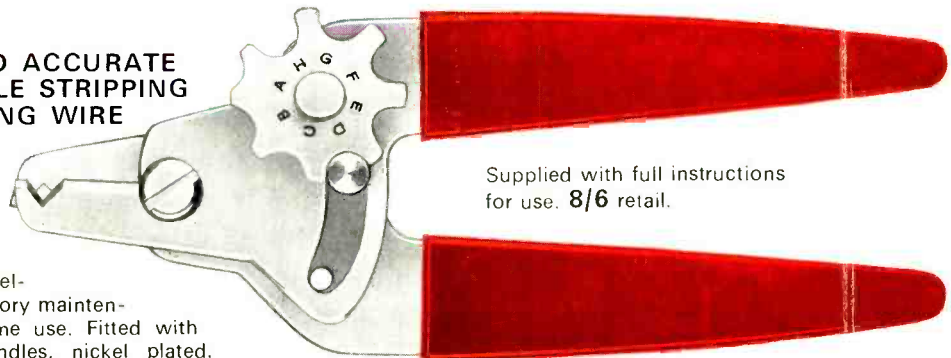

Supplied with full instructions for use. **8/6** retail.

Obtainable from all good Electrical and Hardware shops. In case of difficulty write to:
MULTICORE SOLDERS LTD., HEMEL HEMPSTEAD, HERTS. TELEPHONE: HEMEL HEMPSTEAD 3636 TELEX: 82363